

# Liebherr Dredging Excavator Technology



**LIEBHERR**



## **Marine application experience**

Since 1954, Liebherr has been designing, manufacturing and servicing crawler mounted excavators used in the toughest applications. All dredging excavators benefit from Liebherr's long-time experience and extensive marine knowledge. This is evident in their customer-focused design with modern engineering solutions. Always considering each customer requirement as specific, Liebherr-Dredging technical advantage is characterized by its high level of flexibility. Engineered for maximum productivity, all machines are designed for the highest rate of availability for unrivaled cost efficiency, while guaranteeing safety and comfort of use for the operators. As a global solution provider, Liebherr-Dredging is counting on its recognised worldwide network for offering the needed proactive service support in order to assist each customer in reaching its objectives as effectively as possible.





Productivity

Page 4



Efficiency

Page 6



Reliability

Page 8



Customer Support

Page 10



Safety

Page 12



Environment

Page 14





#### Wide Range of Attachments

- From -15 m / -49 ft to -26 m / -79 ft depth
- Adapted for severe marine conditions
- Optimized for maximum bucket capacity, digging depth and dump height
- Special requirement can be developed



# Productivity

Liebherr provides a full range of products with a complete and unique range of attachments and custom-tailored solutions for any application. Operating weights from 100 t to 580 t (121,500 lb to 1,200,000 lb) and power ratings from 500 kW to 1750 kW (701 HP to 1,750 HP) are available.

## Fast Cycle Times

The Liebherr dredging excavator is equipped with a Close-Loop Swing Circuit. Contrary to machines using open hydraulic circuits, this enables the maximum swing torque whilst retaining the full oil flow for the attachment movement. The use of an independent swing circuit results in faster arm motions even during swing movements contributing to faster cycle times. The mode selector enables the operator to adjust the machine power to match the application for the best performances.

## High Digging Forces

Designed for high-performing mechanical force distribution, the production-tailored attachment delivers high digging and lifting forces. Integrating Liebherr-made cylinders, the Liebherr dredging excavator attachment ensures the highest crowd and breakout forces to perform even in the most demanding and intensive job conditions.

## Hydraulic Dredging Control System

The power of the hydraulic technology combined with the high precision from the electronic control contribute to promote energy optimization. The high pressure of the hydraulic excavator system can be used by the barge to offer a uniquely powerful hydraulic source.

## Working Environment Total Control

The extra-large dredging cab offers ideal working conditions. Designed with a one-piece windscreen, the cab supplies large panoramic windows providing an outstanding visibility over the whole equipment. Two outside cameras allow a 360° view around the equipment. Long-distance lighting allows the operator to properly view his area of work for the most efficient loading.

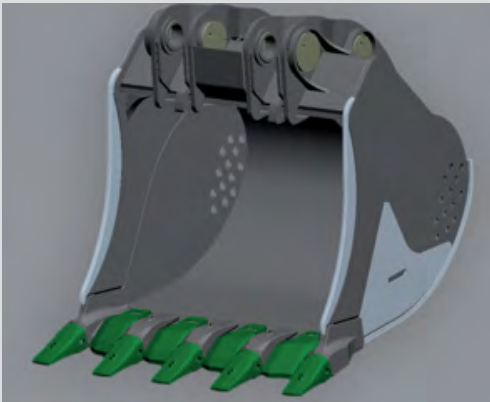

### Specific Dredging Bucket

- Specially designed for the customer needs
- Well-balanced for depth and forces

### Close Loop Swing Circuit for Fast Cycle Times

- Independent hydraulic swing circuit
- High pressure system
- Simultaneous attachment motions possible during swinging





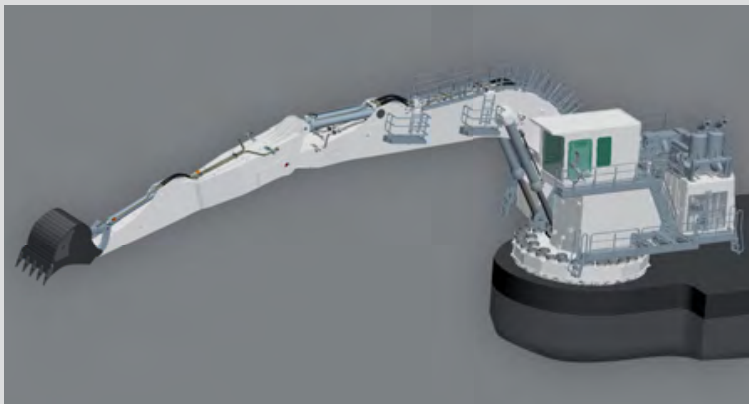

#### **Design for Marine Environment**

- Special seawater-resistant resisting paint
- Waterproof electric sytem
- Integrated environmental protections
- Built-up against the marine conditions
- Hydraulic cylinders fitted with nickel chrome coating
- Pressurized attachment components (optional)
- Bucket cylinder protection
- Platforms and handrails to access maintenance points
- Greasing system in stainless steel



# Efficiency



Due to innovative technological solutions and based on operators feedback, Liebherr dredging excavators are ideally suited for marine engineering projects. High quality design and outstanding workmanship increase life expectancy even under extreme conditions.

## Cooling System Efficiency

The oversized independent oil- and water coolers, in combination with low energy consumption fans and on-demand cooling controls, enable the maximization of available power for digging process.

## Pontoon Hydraulic Oil Supply

Assuming hydraulic excavators and pontoon vessels are fully integrated systems, hydraulic powerpacks supply hydraulic oil for pontoon vessel consumers through the hydraulic excavator rotary connection.

## Liebherr Elastic Foundation Technology

To provide the best working conditions, Liebherr has developed a unique elastic base to absorb all forces with rubber elements. The elastic foundation technology offers the optimum support between the pontoon vessel and the dredging excavator to maximize the life expectancy of the pontoon deck structure and the structural parts of excavator.

## Superior Operator Comfort

The large and spacious cab offers ideal working conditions and optimal operator comfort. Mounted on shock absorbers, the cab design reduces vibrations and limits noise pollution to provide a quiet environment.

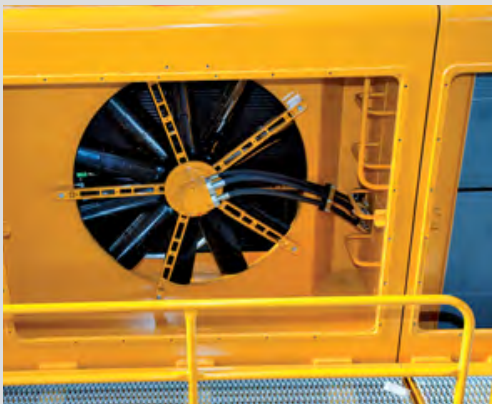

### Power Consumption Efficiency

- Pressureless boom down function
- Optimized hydraulic piping and hoist layout
- Oversized cooling system with low fan power consumption

### Liebherr Elastic Foundation

- Better operator comfort
- Shock absorption
- Optimal force distribution and introduction into the pontoon deck







#### **Liebherr Vertical Integration**

Liebherr-made integrated major parts are:

- Hydraulic cylinders
- Hydraulic pumps
- Hydraulic motors
- Pump gears
- Electronics
- Large diameter bearing (swing ring)
- Swing drives





# Reliability



More than 50 years of experience in designing and manufacturing hydraulic excavators are the basis for the outstanding reliability of the Liebherr dredging excavators. The machines combine innovative technologies, design optimization and long-life components. This ensures a durable performance throughout the machine life.

## Liebherr Vertical Integration

As an original equipment manufacturer, Liebherr has a solid background in the development and the production of high quality strategic components designed for the most severe applications. Dredging excavators integrate Liebherr robust components (cylinders, swing ring, swing drives, etc.) all of which are developed, manufactured and controlled in-house to contribute to the reliability of the whole machine.

## Strengthened Attachment Design

Liebherr design processes include the latest and product-specific numerical engineering tools and the most advanced welding techniques. Reinforced with strategically located casting in high stress areas, all attachments are designed to eliminate high stress concentration to protect against the severe conditions of marine applications.

## Quality Management

Liebherr quality processes commence with machine design and simulation. Relying on certified internal auditors and on a highly qualified workforce, all manufacturing process steps are leading in order to provide the most comprehensive control, monitoring and traceability. Global quality evaluation management enables Liebherr to exceed customers' expectations.

## Machine Reliability Survey

The Liebherr-Dredging Reliability Engineering Group is dedicated to evaluating the reliability performance for the machine. Based on the systematic evaluation of the machines behaviour in the field by the measurement of key performance indicators and the capitalisation of experience, Liebherr is constantly looking for new possibilities for improvement.

## Engine Experience

Liebherr's strong partnership with engine OEMs for mining excavator range is a key advantage in developing dredging machine engine reliability.

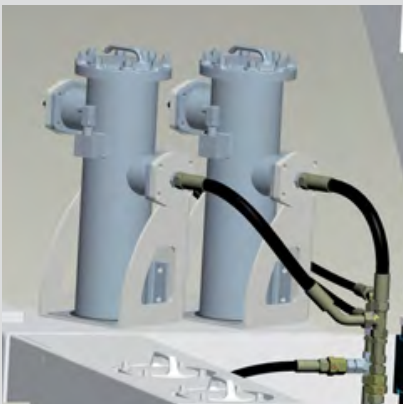

### By-pass Filtration

- Hydraulic oil is filtered with water separator (2  $\mu$ m)

### Dredging Electric Option

- Non polluting
- Better uptime
- Increased component life

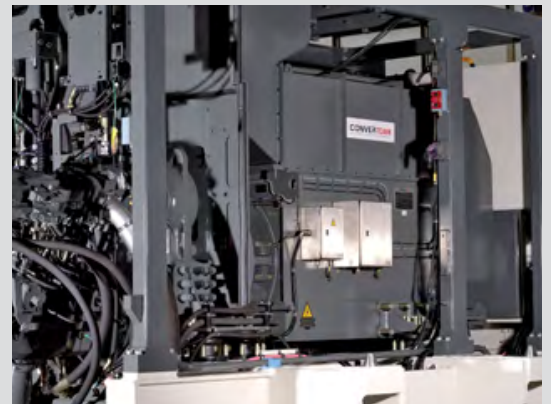





#### **From-Cradle-To-Grave Support**

- Customer-specific requirement study
- Collaborative solution development
- On-site machine assembly
- On-site machine settings
- Training program on / off site
- Machine performance monitoring
- Spare parts supply
- Parts remanufacturing facilities





# Customer Support



As a global solution provider, Liebherr is more than a hydraulic dredging excavator manufacturer. Liebherr customer support fosters a permanent dialogue with each customer in order to provide tailor-made answers to their specific projects and site requirements. Liebherr offers a robust partnership throughout the lifetime of the machine, and behaves as your dredging partner.

## Liebherr-Dredging Partnership

Liebherr-Dredging is present worldwide through an established network made of Liebherr affiliates and exclusive dealers ideally located in order to support customers. These partners behave as customer's allies helping to dredge efficiently and productively. Liebherr parts and service support follow the machine anywhere with close international logistic platforms ensuring parts supply.

## Customized Service Support On-Ship

Depending on specific requirements, Liebherr offers tailored support solutions integrating parts exchange and management agreement, service and maintenance on site or maintenance management agreements. Liebherr's highly-trained service personnel ensures proper day-to-day and scheduled maintenance and promotes emergency service to achieve the highest possible availability and productivity throughout the life of the equipment.

## Complete Training Programs

The Liebherr training team provides operator and maintenance staff with the most suitable program to allow cost-efficient and safe operations. The Liebherr Dredging Training Center is equipped with service simulators and actual dredging equipment for the most concrete and competence-based learning. Based on the technical expertise of its training team, Liebherr also offers customized on-site training courses.

## Service Engineering Dedicated

Liebherr design and field service engineers accompany the excavator throughout the machine's lifetime. Liebherr sales and service organizations and the product engineering groups the the Liebherr factories provide fast and proactive support to the dredging industry by always favoring win-win situations.



## Liebherr Dredging Exchange Components

Exchange and repair programs for components are conducted by Liebherr-certified rebuild facilities using the latest OEM rebuild specifications and the complete range of genuine Liebherr parts to ensure:

- Value: significantly reducing total cost of ownership
- Quality: guaranteed as-new performance and reliability
- Availability: global network of components rebuild facilities





#### Liebherr Service Front Access

- Efficient time usage during maintenance
- Specially designed for dredging
- Easy to access and use

#### Fire Fighting System (optional)

- Preventive and active system against fire
- Fast access to shut down the machine







# Safety



All dredging excavators provide uncompromising safety for operators and maintenance crews. Equipped with the service flap easily accessible from the front and integrating wide accesses, all dredging excavators offer quick and safe maintenance.

## Easy Inspection & Components Replacement

In addition to being easily accessible, all component locations have been chosen to make the inspection and the replacement as effortless and safe as possible. All dredging excavators are equipped with robust hinged louvers for easy cleaning and maintenance. Numerous service lights are located in the main service areas to maintain suitable conditions for maintenance, day or night.

## Powerpack Provision of Security

The Powerpack integrates a firewall protection system separating the engine from the pumps. This prevents any risk of oil splashing into the engine compartment in order to avoid fires. The turbochargers and the exhaust system are mounted with heat insulation, and high resistant hydraulic hoses are used.

## Machine Access & Security

The dredging machine is accessible via four different accesses. Each access is equipped with integrated guardrails, including an emergency stop switch. An integrated system allows control of the fall of the boom in emergency situations in order to protect the barge and environment.



### Marine Operator's Cab:

An array of features:

- Tinted laminated safety glass
- Adjustable air suspended seat
- A/C with dust filter in fresh air / recirculated
- Solasafe sunblind
- Enlarged cab
- Additional cable trays & brackets available for customer-specific equipment





#### Automatic Idle Control

Electronic idle control of the engine results in:

- Less energy consumption
- Less load on the engine
- Reduced emissions
- More comfort to the operator (reduced noise pollution)







# Environment



Liebherr considers the preservation of the environment as a major objective for the present and future. Sustainability underpins Liebherr's machines; from the selection of raw materials to the manufacturing process employed. Liebherr provides solutions that allow customers to balance high performance with environmental consciousness.

## Minimize Impact on the Environment

### Optimized Fuel Consumption

The combination of the electronic control of the hydraulic system and engine output contributes to improve the fuel efficiency depending on job intensity. The Automatic Idling System contributes to low the engine speed when the machine is not working. When less power is required for the job, the Eco-Mode can be selected via the machine monitor panel in order to reduce the load on the engine in order to improve the fuel efficiency and reduce the rate of carbon emissions.

### Controlled Emission Rejections

The Liebherr-Dredging excavators offer fuel efficient operation meeting the latest emission standard in being powered with the USA/EPA IMO. They can be powered on request with the fuel-optimized engine version. The Power Systems offer the best control of the machine impact on the environment contributing to cost efficiency without compromising productivity.

## Sustainable Design and Manufacturing Process

### Extended Components and Fluids Lifetime

Liebherr is constantly working on ways to extend component life. Through the Exchange Components program, superior lubrication systems, and the reinforcement of parts under stress, Liebherr can reduce frequency of part replacement. The result is a minimized environmental impact and a lower overall cost of ownership.

### Product Life-Cycle Management

Subject to the stringent European Program for the regulation of the use of chemical substances in the manufacturing process (REACH\*), Liebherr undertakes a global evaluation to minimize the impact of hazardous materials.

\*REACH is the European Community Regulation on chemicals and their safe use (EC1907/2006). It deals with the Registration, Evaluation, Authorization and Restriction of Chemical Substances.



### Sustainable Manufacturing Process

With an ever-present green focus, Liebherr contributes to sustainable development:

- Systematic risk analysis for new materials qualification
- Promoted recovery waste management
- Controlled non-recyclable waste elimination
- Eco-friendly material selection (95% of material used on machine is recyclable)

# 100t Class

## P 984

Operating Weight: 110.000 kg / 242,500 lb  
Bucket Capacity: 2,00 - 7,00 m<sup>3</sup> / 2.6 - 9.2 yd<sup>3</sup>  
Engine Output: 523 kW / 701 HP  
Digging Depth: up to 18,3 / 60 ft





# Mid Size Class

Operating Weight: 215.000 kg / 474,000 lb  
Bucket Capacity: 2,50 - 8,50 m<sup>3</sup> / 3.3 - 11.1 yd<sup>3</sup>  
Engine Output: 960 kW / 1,287 HP  
Digging Depth: up to 22,9 m / 75.1 ft

**P 9250**

Operating Weight : 270.000 kg / 595,250 lb  
Bucket Capacity: 3,00 - 15,30 m<sup>3</sup> / 3.9 - 20.0 yd<sup>3</sup>  
Engine Output: 1.120 kW / 1,500 HP  
Digging Depth: up to 23 m / 75.5 ft

**P 9350**





# Ultra Class

## P 995

Operating Weight: 398.000 kg / 877,440 lb  
Bucket Capacity: 8,50 - 25,00 m<sup>3</sup> / 11.1 - 32.7 yd<sup>3</sup>  
Engine Output: 1.750 kW / 2,346 HP  
Digging Depth: up to 26,3 m / 86.3 ft

## P 9800

Operating Weight: 580.000 kg / 1,278,700 lb  
Bucket Capacity: 12,00 - 30,00 m<sup>3</sup> / 15.7 - 39.2 yd<sup>3</sup>  
Engine Output: 2.984 kW / 4,000 HP  
Digging Depth: up to 27,3 m / 89.6 ft





# Technical Data



## Engine

Designed for ambient temperature range from  $-20\text{ }^{\circ}\text{C}$  up to  $50\text{ }^{\circ}\text{C}/-4\text{ }^{\circ}\text{F}$  up to  $122\text{ }^{\circ}\text{F}$  (with optional cold kit down to  $-40\text{ }^{\circ}\text{C}/-40\text{ }^{\circ}\text{F}$ ).

Cooling \_\_\_\_\_ Water-cooled with hydrostatic fan drive  
 Air cleaner \_\_\_\_\_ Dry-type air cleaner with pre-cleaner, primary and safety elements, automatic dust discharge  
 Engine idling \_\_\_\_\_ Electronically controlled  
 Fuel tank \_\_\_\_\_ 26 hours operation



## Electric System

Electric isolation \_\_\_\_\_ Easy accessible battery isolation  
 Lightings \_\_\_\_\_ Standard light package for 24 hours of operation  
 Floodlights \_\_\_\_\_ Marine type 24 V floodlights made by Aqua Signal (halogen standard & HID or LED optional)  
 Standstill heating \_\_\_\_\_ Electrical cabinets and instrumentation boxes in the cabin equipped with 24 V standstill heaters to prevent water damage due to condensation  
 Electrical wiring \_\_\_\_\_ Heavy duty execution in IP65 standard for operating conditions from  $-50\text{ }^{\circ}\text{C}$  to  $100\text{ }^{\circ}\text{C}/-58\text{ }^{\circ}\text{F}$  to  $212\text{ }^{\circ}\text{F}$



## Hydraulic System

High pressure safety filters after each high pressure pump ( $200\text{ }\mu\text{m}$ ), full flow return filters ( $15/5\text{ }\mu\text{m}$ ), leak oil filters ( $15/5\text{ }\mu\text{m}$ )  
 Hydraulic pump for attachment \_\_\_\_\_ Variable flow axial piston pumps  
 Pump management \_\_\_\_\_ Electronically controlled pressure and flow management with oil flow optimisation  
 Hydraulic cooler \_\_\_\_\_ Separated cooler, temperature controlled fan driven via hydraulic piston motors  
 MODE selection \_\_\_\_\_ Adjustment of machine performance and the hydraulics via a mode selector to match application  
     ECO \_\_\_\_\_ For economical operation (can be combined with fuel optimized setting)  
     POWER \_\_\_\_\_ For maximum digging power and heavy duty jobs



## Pontoon Hydraulic Oil Supply

Design \_\_\_\_\_ A hydraulic rotary connection is installed on the excavator to supply hydraulic oil to the pontoon consumers  
 Flow control \_\_\_\_\_ The required oil capacity will be regulated by the pump oil flow regulators. An interfacing between the pontoon's hydraulic system and the excavator hydraulic system is provided



## Hydraulic Controls

Power distribution \_\_\_\_\_ Via monoblock control valves with integrated primary relief valves and flanged on secondary valves  
 Flow summation \_\_\_\_\_ To attachment  
 Closed-loop circuit \_\_\_\_\_ For uppercarriage swing drive  
 Electro-hydraulic servo control \_\_\_\_\_  
 Attachment and swing \_\_\_\_\_ Electronic optimized control via proportional valves



## Swing Drive

Drive by \_\_\_\_\_ Liebherr axial piston motors  
 Transmission \_\_\_\_\_ Liebherr planetary reduction gears  
 Swing ring \_\_\_\_\_ Liebherr, sealed single race ball bearing swing ring, internal teeth  
 Swing speed \_\_\_\_\_  $0 - 6\text{ rpm}$  (according to machine model)  
 Parking brake \_\_\_\_\_ Wet multi-disc brakes, spring applied, hydraulically released



## Elastic Foundation

Design \_\_\_\_\_ The excavator swing ring is mounted on the elastic foundation which is connected to the pontoon deck via oversized, torque-resistant shock mounts designed for optimum force management. They absorb shocks and stresses created by the actions of the excavator as well as forces generated by wave action and barge movement  
 Fastening \_\_\_\_\_ Bolted to the pontoon deck structure



## Operator's Cab

Cab \_\_\_\_\_ Sound insulated, tinted windows. Front window armored glass, side window sliding window  
 Operator's seat \_\_\_\_\_ Air suspended, body-contoured with shock absorber, adjustable to operator's weight  
 Joysticks \_\_\_\_\_ Joystick levers integrated into armrest of seat, armrest adjusted to seat position  
 Condition monitoring \_\_\_\_\_ Machine condition monitoring system with error reporting and operational information  
 Rear vision system \_\_\_\_\_ Camera installation on counterweight and right-hand side of the uppercarriage displayed over the LCD-display  
 Heating system \_\_\_\_\_ Standard automatic air conditioning, combined cooler/heater, additional dust filter in fresh air/recirculated

# Technical Data



## Service Station (Centralized Couplings)

Quick release couplings are provided for:

- Fuel filling
- Window wash water
- Engine oil draining and filling
- Hydraulic oil filling
- SAT draining and filling
- Grease filling

All couplings in the service station are “Wiggins” type



## Central Lubrication System

- Type \_\_\_\_\_ Lincoln Centromatic lubrication system, for the entire attachment/swing ring bearing and teeth
- Grease pumps \_\_\_\_\_ Lincoln Powermaster pump plus separate P203 pump for swing ring teeth
- Refill \_\_\_\_\_ Via the service flap for both containers, fill line with grease filters



## Attachment

- Design \_\_\_\_\_ Box type structure with large steel castings in all high stress areas  
Specially designed for dredging applications stress relieved
- Pivot points \_\_\_\_\_ Fully sealed, all bearings equipped with wear resistant steel-bushings and connected to the central lubrication system
- Hydraulic cylinders \_\_\_\_\_ Liebherr designed with NiCr-plated (50/30 µm) piston rods  
Hydraulic piston cushioning to protect cylinders from shock  
Bucket cylinder rod guard to prevent damage from rocks
- Drain Plugs \_\_\_\_\_ Boom and stick equipped with drain plugs
- Service access \_\_\_\_\_ Access ladder on the boom  
Service platforms on both sides of the boom to facilitate maintenance
- Hammer & grapple application available (optional)



## Fire Suppression System (Option)

Automatic fire suppression system Powder/Foam manufactured by ANSUL according to the latest requirements, including local commissioning and approval by the manufacturer



## Safety Systems

- Emergency stop switches \_\_\_\_\_
- In hydraulic compartment
  - In engine compartment
  - In operator cab
  - Inputs provided to the pontoon for external emergency stop switches
  - Access ladder
- Emergency control \_\_\_\_\_ Emergency lowering of the attachment to the pontoon deck
- Emergency boom lift package \_\_\_\_\_ The attachment can be raised from the sea-bed with stopped engine via a separate hydraulic pump provided by the owner. Hydraulic connections are provided for the hoist cylinders
- Load holding valves on hoist cylinders \_\_\_\_\_ Boom lowering control device



## Marine Features

- Corrosion protection coating \_\_\_\_\_
- Maritime painting
  - Galvanized catwalk & handrails (painting in option)
  - Stainless steel greasing system
- Hydraulic oil filtration \_\_\_\_\_ By-pass filters with water separator (2 µm)
- Conservation \_\_\_\_\_ Conservation corrosion protection
- Splash water protection \_\_\_\_\_ The underside of the upper carriage is water-tight
- Welding \_\_\_\_\_ All components are completely welded unless the access of certain structures does not allow for complete welds. These are sealed prior to painting to prevent the intrusion of water
- Used oil tank \_\_\_\_\_ An oil collector is placed on the boom to drain the hydraulic hoses in a used oil tank placed in front of the excavator in case of attachment changing



# Technical Data

P 984

Boom		Stick		Bucket size		Max depth		Work depth		Stroke at work depth		Digging force (ISO 6015)		Breakout force (ISO 6015)	
m	ft	m	ft	m <sup>3</sup>	yd <sup>3</sup>	m	ft	m	ft	m	ft	kN	lbf	kN	lbf
9,2	30.2	4,5	14.8	7,0	9.2	10,0	32.8	9,0	29.5	5,0	16.4	346	77,784	550	123,645
		5,6	18.4	6,2	8.1	11,1	36.4	10,0	32.8	5,8	19.0	300	67,443	550	123,645
		6,8	22.3	5,5	7.2	12,0	39.4	11,0	36.1	6,0	19.7	273	61,373	405	91,048
11,0	36.1	4,5	14.8	5,5	7.2	12,2	40.0	11,0	36.1	5,1	16.7	346	77,784	550	123,645
		5,6	18.4	4,7	6.1	13,3	43.6	12,0	39.4	6,2	20.3	300	67,443	550	123,645
		6,8	22.3	4,3	5.6	14,2	46.6	13,0	42.7	6,4	21.0	273	61,373	405	91,048
		8,0	26.2	3,5	4.6	15,2	49.9	14,0	45.9	5,9	19.4	245	55,078	329	73,962
13,0	42.7	5,6	18.4	3,0	3.9	15,0	49.2	14,0	45.9	5,4	17.7	300	67,443	550	123,645
		6,8	22.3	2,6	3.4	16,1	52.8	15,0	49.2	6,2	20.3	273	61,373	405	91,048
		8,0	26.2	2,2	2.9	17,0	55.8	16,0	52.5	6,5	21.3	245	55,078	329	73,962
		9,5	31.2	2,0	2.6	18,3	60.0	17,0	55.8	8,2	26.9	217	48,784	223	50,132

Distance between water level and base plate: 1.000 mm/3'3"

Bucket size given for bulk density: 1,8 t/m<sup>3</sup>/3,035 lb/yd<sup>3</sup>

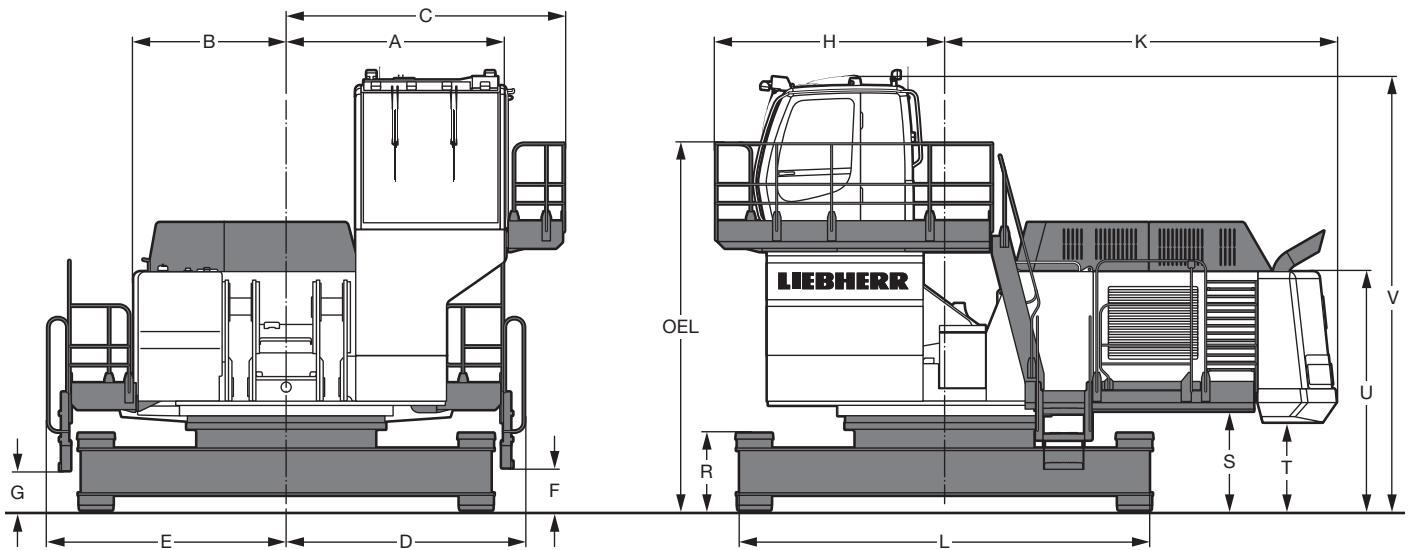

	mm/ft in
A	2.610/ 8' 6"
B	1.825/ 5'11"
C	3.340/10'11"
D	2.860/ 9' 4"
E	2.860/ 9' 4"
F	505/ 1' 7"
G	470/ 1' 6"
H	2.745/ 9'

	mm/ft in
K	4.685/15' 4"
L	4.905/16' 1"
R	920/ 3'
S	1.180/ 3'10"
T	1.050/ 3' 5"
U	2.855/15' 8"
V	5.200/17'
OEL	Operator's Eye Level 4.370/14' 4"

# Technical Data

P 9250

Boom		Stick		Bucket size		Max depth		Work depth		Stroke at work depth		Digging force (ISO 6015)		Breakout force (ISO 6015)	
m	ft	m	ft	m <sup>3</sup>	yd <sup>3</sup>	m	ft	m	ft	m	ft	kN	lbf	kN	lbf
14,8	48.6	6,00	19.7	7,2	9.4	15,9	52.2	14,0	45.9	6,60	21.7	620	139,382	750	168,607
		7,10	23.3	8,5	11.1	16,7	54.8	15,0	49.2	6,80	22.1	558	125,443	550	123,645
		9,45	31.0	7,0	9.2	19,0	62.3	18,0	59.1	6,60	21.7	451	101,389	550	123,645
		11,00	36.1	5,5	7.2	20,4	66.9	19,0	62.3	8,50	27.9	404	90,823	550	123,645
16,5	54.1	6,00	19.7	4,5	5.9	18,1	59.4	16,0	52.5	7,00	23.0	620	139,382	750	168,607
		7,10	23.3	6,5	8.5	18,9	62.0	17,0	55.8	7,00	23.0	558	125,443	550	123,645
		9,45	31.0	3,9	5.1	21,2	69.6	20,0	65.6	6,60	21.7	451	101,389	550	123,645
		11,00	36.1	3,2	4.2	22,5	73.8	22,0	72.2	4,25	13.9	404	90,823	550	123,645
18,0	59.1	7,10	23.3	3,5	4.6	20,7	67.9	19,0	62.3	6,70	22.0	550	123,645	550	123,645
		9,45	31.0	2,5	3.3	22,9	75.1	22,0	72.2	6,40	21.0	451	101,389	550	123,645

Distance between water level and base plate: 1.000 mm/3'3"

Bucket size given for bulk density: 1,8 t/m<sup>3</sup>/3,035 lb/yd<sup>3</sup>

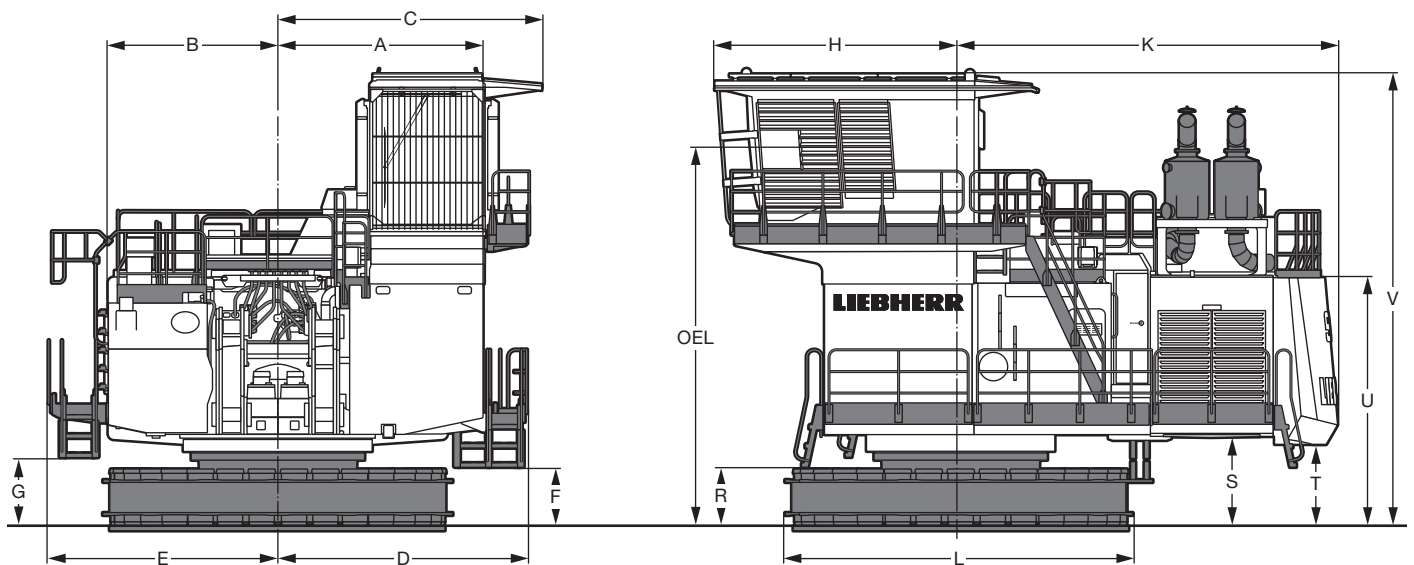

	mm/ft in
A	3.320/10' 10"
B	2.750/ 9'
C	4.285/14'
D	4.050/13' 3"
E	3.725/12' 2"
F	950/ 3' 1"
G	1.105/ 3' 7"
H	3.890/12' 9"

	mm/ft in
K	6.190/20' 3"
L	5.640/18' 5"
R	920/ 3'
S	1.530/ 5'
T	1.400/ 4' 7"
U	4.100/15' 8"
V	7.400/24' 3"
OEL	Operator's Eye Level 6.130/20' 1"



# Technical Data

P 9350

Boom		Stick		Bucket size		Max depth		Work depth		Stroke at work depth		Digging force (ISO 6015)		Breakout force (ISO 6015)	
m	ft	m	ft	m <sup>3</sup>	yd <sup>3</sup>	m	ft	m	ft	m	ft	kN	lbf	kN	lbf
12,0	39.4	4,2	13.8	15,3	20.0	11,7	38.4	10,0	32.8	5,5	18.0	870	195,584	1.020	229,305
		6,5	21.3	13,5	17.7	14,0	45.9	12,0	39.4	6,4	21.0	675	151,746	1.020	229,305
15,0	49.2	4,0	13.1	8,0	10.5	13,9	45.6	12,0	39.4	6,3	20.7	965	216,941	980	220,313
		6,5	21.3	7,0	9.2	16,4	53.8	14,0	45.9	6,0	19.7	712	160,064	980	220,313
		7,1	23.3	9,0	11.8	16,9	55.4	15,0	49.2	7,1	23.3	652	146,575	520	116,901
19,0	62.3	9,45	31.0	8,0	10.5	19,2	63.0	18,0	59.1	7,0	23.0	526	118,249	520	116,901
		7,1	23.3	5,0	6.5	20,6	67.6	19,0	62.3	6,9	22.6	567	127,467	550	123,645
		9,45	31.0	3,0	3.9	23,0	75.5	22,0	72.2	6,5	21.3	456	102,513	550	123,645

Distance between water level and base plate: 1.000 mm/3'3"

Bucket size given for bulk density: 1,8 t/m<sup>3</sup>/3,035 lb/yd<sup>3</sup>

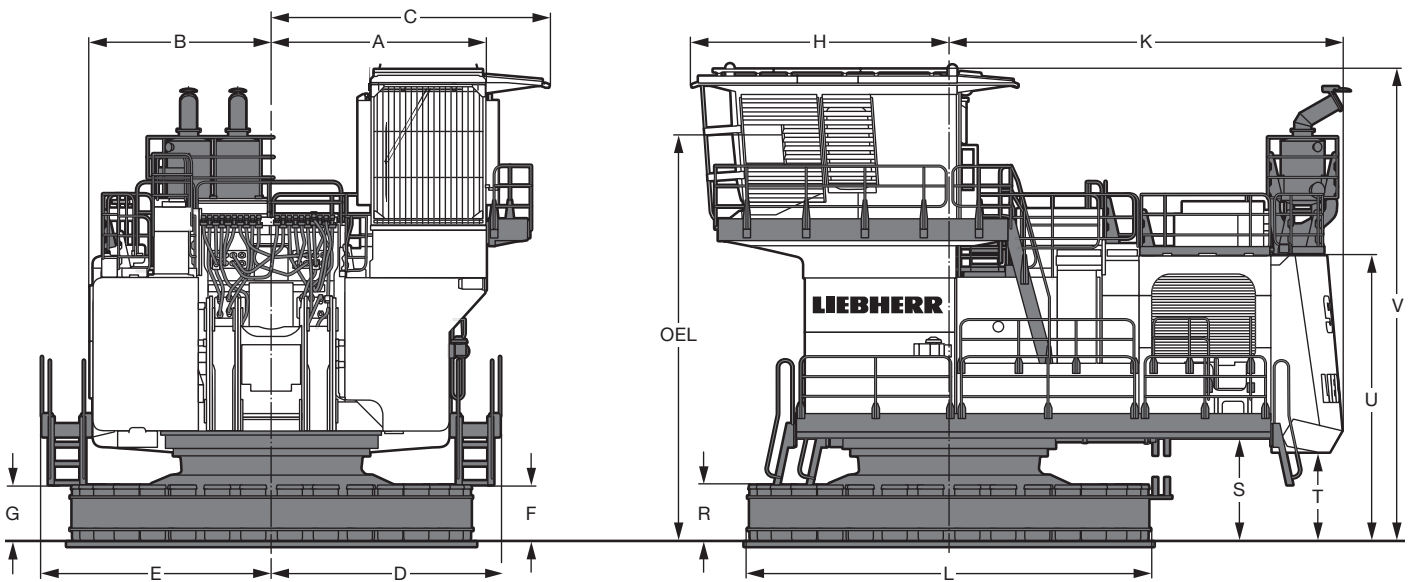

	mm/ft in
A	2.950/ 9' 8"
B	3.505/11' 5"
C	4.530/14'10"
D	3.745/12' 3"
E	3.745/12' 3"
F	925/ 3'
G	925/ 3'
H	4.190/13' 8"

	mm/ft in
K	6.400/20'11"
L	6.560/21' 6"
R	925/ 3'
S	1.680/ 5' 6"
T	1.455/ 4' 9"
U	4.655/15' 8"
V	7.700/25' 3"
OEL	Operator's Eye Level 6.625/21' 8"

# Technical Data

P 995

Boom		Stick		Bucket size		Max depth		Work depth		Stroke at work depth		Digging force (ISO 6015)		Breakout force (ISO 6015)	
m	ft	m	ft	m <sup>3</sup>	yd <sup>3</sup>	m	ft	m	ft	m	ft	kN	lbf	kN	lbf
13,5	44.3	4,5	14.8	25,0	32.7	13,4	44.0	11,0	36.1	6,5	21.3	1.160	260,778	1.270	285,507
		6,5	21.3	18,0	23.5	15,0	49.2	13,0	42.7	7,5	24.6	965	216,940	805	180,971
		8,0	26.2	16,5	21.6	16,5	54.1	15,0	49.2	5,9	19.4	840	188,889	825	185,467
		9,6	31.5	15,3	20.0	18,0	59.1	16,0	52.5	8,5	27.9	740	166,358	855	192,211
16,0	52.5	4,5	14.8	13,0	17.0	16,2	53.2	14,0	45.9	7,2	23.6	1.160	260,778	1.270	285,507
		6,5	21.3	14,5	19.0	18,0	59.1	16,0	52.5	6,7	22.0	975	219,188	825	185,467
		8,0	26.2	13,0	17.0	19,2	63.0	18,0	59.1	5,5	18.0	850	191,087	830	186,591
		9,6	31.5	11,0	14.4	21,0	68.9	20,0	65.6	4,8	15.7	735	165,234	830	186,591
19,0	62.3	6,5	21.3	9,0	11.8	20,6	67.6	18,0	59.1	6,1	20.0	1.015	228,181	975	219,188
		8,0	26.2	8,0	10.5	21,8	71.5	20,0	65.6	7,9	25.9	885	198,955	945	212,444
		9,6	31.5	7,0	9.2	23,6	77.4	22,0	72.2	6,4	21.0	755	169,730	890	200,080
22,0	72.2	9,5	31.2	8,5	11.1	26,3	86.3	24,0	78.7	8,4	27.6	450	101,164	575	129,265

Distance between water level and base plate: 1.000 mm / 3'3"

Bucket size given for bulk density: 1,8 t/m<sup>3</sup> / 3,035 lb/yd<sup>3</sup>

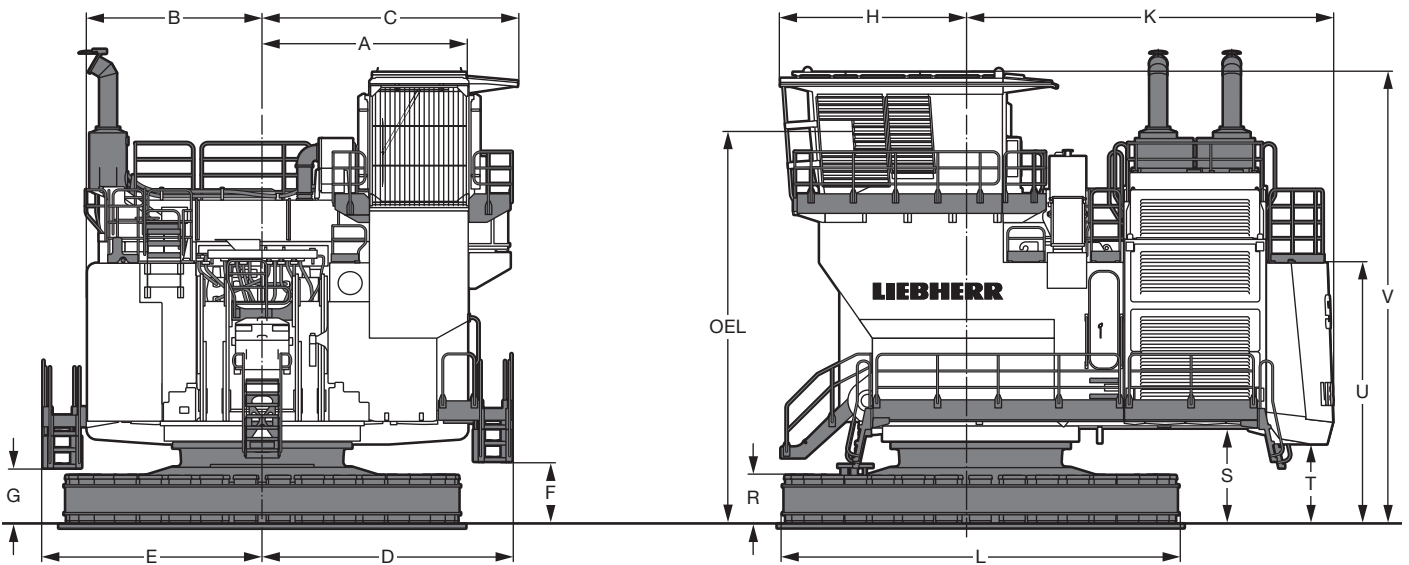

	mm/ft in
A	3.900/12' 9"
B	3.315/10' 10"
C	4.830/15' 10"
D	4.730/15' 6"
E	4.155/13' 7"
F	1.185/ 3' 10"
G	1.060/ 3' 5"
H	3.520/11' 6"

	mm/ft in
K	6.925/22' 8"
L	7.500/24' 7"
R	920/ 3'
S	1.860/ 6' 1"
T	1.515/ 4' 11"
U	4.940/15' 8"
V	8.565/28' 1"
OEL	Operator's Eye Level 7.500/24' 7"



# Technical Data

P 9800

Boom		Stick		Bucket size		Max depth		Work depth		Stroke at work depth		Digging force (ISO 6015)		Breakout force (ISO 6015)	
m	ft	m	ft	m <sup>3</sup>	yd <sup>3</sup>	m	ft	m	ft	m	ft	kN	lbf	kN	lbf
17,5	57.4	7,0	23.0	30,0	39.2	17,2	56.4	15,0	49.2	8,1	26.6	1.265	284,383	1.268	285,058
		9,5	31.2	25,0	32.7	19,7	64.6	18,0	59.1	8,0	26.2	1.023	229,980	1.250	281,011
22,0	72.2	9,5	31.2	16,5	21.6	24,1	79.1	22,0	72.2	8,7	28.5	1.043	234,476	981	220,538
		13,0	42.7	12,0	15.7	27,3	89.6	26,0	85.3	8,8	28.9	824	185,243	844	189,739

Distance between water level and base plate: 1.000 mm/3'3"

Bucket size given for bulk density: 1,8 t/m<sup>3</sup>/3,035 lb/yd<sup>3</sup>

# The Liebherr Group of Companies



## Wide Product Range

The Liebherr Group is one of the largest construction equipment manufacturers in the world. Liebherr's high-value products and services enjoy a high reputation in many other fields. The wide range includes domestic appliances, aerospace and transportation systems, machine tools and maritime cranes.

## Exceptional Customer Benefit

Every product line provides a complete range of models in many different versions. With both their technical excellence and acknowledged quality, Liebherr products offer a maximum of customer benefits in practical application.

## State-of-the-art Technology

To provide consistent, top quality products, Liebherr attaches great importance to each product area, its components and core technologies. Important modules and components are developed and manufactured in-house, for instance the entire drive and control technology for construction equipment.

## Worldwide and Independent

Hans Liebherr founded the Liebherr family company in 1949. Since that time, the enterprise has steadily grown to a group of more than 130 companies with over 38,000 employees located on all continents. The corporate headquarters of the Group is Liebherr -International AG in Bulle, Switzerland. The Liebherr family is the sole owner of the company.

[www.liebherr.com](http://www.liebherr.com)