

# Mining Excavator **R 9800**

Operating Weight with  
Backhoe Attachment:  
**800 tonnes / 882 tons**

Shovel Attachment:  
**810 tonnes / 893 tons**

Engine:  
**2,984 kW / 4,000 HP**

Loading Capacity:  
**75 – 85 t/pass**  
**38 – 52 m<sup>3</sup>**

**83 – 94 t/pass**  
**49.7 – 68 yd<sup>3</sup>**



# **LIEBHERR**



## R 9800

### Operating Weight with Backhoe Attachment:

800 tonnes/882 tons

### Shovel Attachment:

810 tonnes/893 tons

### Engine:

2,984 kW/4,000 HP

### Loading Capacity:

75 – 85 t/pass

38 – 52 m<sup>3</sup>

83 – 94 t/pass

49.7 – 68 yd<sup>3</sup>



### Productivity

Working Harder and Faster



### Efficiency

Moving More for Less







### Reliability

Ready to Work  
When You Need It



### Customer Service

Worldclass Support,  
Everywhere, Every Day



### Safety

Protecting Your Most  
Important Assets



### Environment

Mining Responsibly







# Productivity



## Working Harder and Faster

The R 9800 is built to outperform all competitors in the Ultra class mining market. As a perfect loader for 200 t, 290 t and 360 t class mining trucks, the R 9800 is the right match for the Liebherr T 284. Developed as the optimal loading tool for large scale mining operations, the R 9800 can achieve the most challenging targets.

## Fast and Precise Movement

### Proven Mining Engine

The R 9800 can be optioned with two versions of diesel drive systems. Customers can choose between Cummins or MTU as their preferred engine partner. An optional electric drive system provides outstanding performance when the machine is used in the most specific conditions. The R 9800 combines flexibility and productivity to meet customer expectations.

### Fast Cycle Time

Rather than using open hydraulic circuit, the R 9800 employs a closed-loop swing circuit to enable maximum swing torque while retaining the full oil flow for the working circuit. The independent swing circuit in combination with the powerful drive system leads to fast arm motion, which contributes to faster cycle times.

### Precise Machine Motions

The R 9800 design integrates the Litronic Plus electronic control system to allow for easy control even when simultaneous movements are required. The patented Liebherr electronic damping system provides controlled end-cushioning for smooth attachment motions.

## High Digging and Lifting Capabilities

### High Digging Forces

Designed for the best mechanical force distribution, the production-tailored attachment delivers high digging and lifting forces. Integrating Liebherr-made cylinders and a wide range of buckets, the R 9800's attachment ensures the highest forces, easy bucket penetration and high fill factor to perform even in the most demanding conditions.

### Power-Oriented Energy Management

The R 9800's attachment is equipped with the pressureless boom down function to enable fast cylinder retraction without the need for pump energy. Intelligent energy management diverts the pump flow during boom lowering, allowing other cylinder motions to operate unimpeded.



### Engine / Motor Options

Twin-Engine available versions:

- Cummins QSK 60 USA/EPA Tier 2/Tier 4i compliant
- MTU 12V4000 USA/EPA Tier 2/Tier 4i compliant
- Fuel consumption optimized version for Cummins and MTU engines (optional)

Electrical Motors (optional):

- 3 phase AC squirrel cage motor
- Voltage on request
- 50 or 60 Hz frequency

### Litronic Plus Electronic Control

A power management system developed to optimize electrical, mechanical, hydraulic power distribution which encompasses:

- Liebherr designed and built power components
- Continuous monitoring of the engine, electrical and hydraulic systems
- Safe, fast and precise control
- Optimum equipment operation
- Productivity and efficiency maximization

### High Performance Option

The optimised design increases the overall production rate without compromising the component life. This remarkable feat is achieved by:

- Decreasing the weight
- Converting attachment weight into payload or bucket protection
- Maintaining the original attachment design life





# Efficiency



## Moving More for Less

The R 9800 follows the Liebherr design philosophy of maximizing the machine's performance by improving the efficiency of all individual subsystems. Engineered for optimum serviceability, the machine is designed to ensure maximum uptime. The R 9800's modern cab creates a comfortable working environment ensuring peak operator performance, every shift.

## Optimized for Maximum Profitability

### Electro-Hydraulic System Efficiency

Liebherr hydraulic technology in combination with the precision of electronic control contributes to the R 9800's energy optimization. The high-pressure hydraulic system and the optimized pipe and hose layout maximize usable power transmission. The hydraulic pumps are electronically managed to provide optimal pressure compensation and oil flow management. The hydraulic system is independently regulated over the engine circuit for the best operational efficiency.

### Independent Cooling System

Oil and water cooling fans are independent and electronically managed. The on-demand cooling control enables to maximize available power for the working process. This technology contributes to maintain sustainable temperature of all the hydraulic components extending their life.

### Closed Loop Swing Circuit

The Liebherr Mining excavators are all equipped with a closed loop swing circuit. Kinetic energy can be saved when the swing motion is used during deceleration, to drive the main and auxiliary pumps, reducing fuel consumption and allowing faster boom lift motion.

## Comfortable Cab for Efficient Work

The large and spacious cab which equips the R 9800 offers ideal working conditions and optimal operator's comfort. Mounted on silent blocks, the cab design reduces vibrations and limit noise pollution to provide a quiet environment.

## Extended Components Lifetime

The R 9800's high pressure hydraulic oil filtration systems remove contaminants from the fluid to offer the highest rate of hydraulic system efficiency. To maintain the oil quality, all return hydraulic oil flow goes through a 15/5  $\mu\text{m}$  fine filtration system. To promote availability, the grease and fuel tanks are sized to considerably extend the time between service intervals.



### Machine Monitoring System

- 10.5" LCD color screen
- Information interface to operator
- On-board diagnostics to service staff
- Real text information
- Long term data storage for maintenance

### Fast Maintenance System

The service flap is hydraulically actuated and accessible from the ground level allowing for fast maintenance:

- Hydraulic oil refill
- Engine oil refill and drainage
- Splitter box and swing gearbox oil exchange
- Attachment/swing ring bearing grease barrel refilling with filters
- Windshield washer water refilling
- Fast fuel refilling line

### Hydraulic System Efficiency

- Optimal oil flow distribution through the valves blocks reducing hydraulic losses
- Reduced pressure drops between pumps and consumers (hydraulic motors/cylinders)
- Allows the combination of the main movements under maximal forces
- Earlier maximal forces generation for an accurate control of the combination of force and cylinder speed
- Increased hydraulic oil cooling efficiency
- Enables fast cycle times





# Reliability



## Ready to Work When You Need It

With over 50 years of innovative thinking, engineering and manufacturing excellence, Liebherr sets the industry standard for advanced equipment design and technology tools to provide the most up-to-date product responding to the requirements of the mining customers.



# Quality: the Liebherr Trademark

## Liebherr Components Integration

As an OEM, Liebherr has built a solid reputation for its development and production of high quality strategic mining components. The R 9800 integrates robust and reliable mining optimized components that are developed, manufactured and controlled by Liebherr ensuring reliability and high performance for the entire machine.

## Machine Reliability Survey

Based on years of experience and the systematic measurement of key performance indicators of the machine behavior in the field, the Liebherr Mining Reliability Engineering Group is constantly seeking new ways to enhance reliability.

## Quality Management Continuous Improvement

Liebherr quality begins during machine design and simulations. Liebherr meets the highest standards for special selections of steels and casting materials. Based on the expertise of certified internal auditors and a highly qualified workforce, all manufacturing process steps are devised to provide the most comprehensive control, monitoring and traceability. Liebherr-Mining Equipment Colmar SAS is ISO 9001 certified.

# Long-lasting Job Performances

## Maximized Components Lifetime

The R 9800 is equipped with an automatic single line lubrication system for the entire attachment and swing ring. All greasing points are suitably protected against external damages. This extends component life and ensures constant performance over the excavator's operational life.

## Rugged Undercarriage Structure

The R 9800 is mounted on a heavy duty fatigue resistant undercarriage. The swing ring is reinforced to provide an improved superstructure weight distribution. Designed and built for both shovel and backhoe configurations, the enlarged undercarriage offers an efficient ground bearing pressure repartition providing the necessary stability and reliability.



### Heavy Duty Undercarriage

- Designed for an optimal weight distribution
- Optimized to provide the best machine stability
- External travel drive for easy maintenance access
- Heavy duty rock protection for travel drive
- Automatic track tensioning system
- Monobloc dual pin combined pad links

### Reliable Attachment Design

- Under slung arch hoses to improve lifetime
- Fatigue resistant steel structure
- Use of the most advanced welding techniques
- Heat treatment to reduce residual stresses and increase fatigue life
- Reinforced with strategically located castings in high stress areas
- Designed for optimized digging force distribution

### Quality Commitment

- Liebherr-Mining Equipment Colmar, France, ISO 9001 certified
- Compliance of materials tested in laboratory
- Quality control during the stages of production
- Vertical integration practice





# Customer Service



## Worldclass Support, Everywhere, Every Day

A daily partner to the customer, for global long term sustainable performances, Liebherr implements tailored solutions from technical support, spare parts and logistics solutions to global maintenance for all types of equipment, all over the world.



## Customer Support

### International Service Organization

The Liebherr Service Support has always been an important focus for the company. Complete service during all operating phases from machinery installation to problem solving, spare parts inventory and technical service. Our service team is close to our customers, delivering the best specific maintenance solution to reduce both equipment downtime and repair costs.

### Complete Training Program

From fully trained technicians to a full team of certified field service engineers, Liebherr commits to provide you with world class training. Dedicated to mining, the Liebherr training team provides maintenance staff training programs to allow cost-efficient and safe operations.

## Remanufacturing

### Reduced Costs and Investment

Over the course of a mining machine's lifetime, major components must be replaced to ensure continued safety, productivity and reliability. The Liebherr Mining Remanufacturing Program offers customers an OEM alternative to purchasing brand new replacement components. Enabling customers to achieve lowest possible equipment lifecycle costs without compromising quality, performance or reliability.

### Fast Availability

A international service network and component facilities worldwide means that component repair services and exchange components are available to customers regardless of their location.

## Parts Business

### Performance

Using genuine Liebherr components ensures the best interaction within your machine, encouraging optimal performance and most effective machine operation and you can be sure that you are in line with the latest improvements and updates on parts providing peace of mind as all major components are tracked in the Liebherr Maintenance Management System.

### Partnership

Liebherr regularly reviews requirements for parts and components for individual machines, based on operating hours, consumption and planned maintenance, resulting in minimized down time for customers. With access to the Global stock via all Liebherr Mining Warehouses, you will improve productivity by having the part you need, when you need it.



### Liebherr Service Tools

Liebherr delivers a wide range of service tools for excavator-specific maintenance ensuring optimal working conditions no matter the size of the component.

- An OEM-certified solution
- Maximized machine uptime
- Cost-efficient maintenance
- Easy machine serviceability
- Uncompromising operational safety

### Repair and Remanufacturing Programs

- Liebherr certified quality
- As-new warranty
- OEM expertise
- Reduced costs and investment
- Fast availability

### Easy Access Parts Online

- Available any time anywhere
- User friendly interface
- Online ordering
- Save time and money





# Safety



## Protecting Your Most Important Assets

The Liebherr R 9800 provides uncompromising safety for operators and maintenance crews. Equipped with the service flap accessible from the ground level and integrating wide open accesses, the R 9800 allows quick and safe maintenance. The R 9800's cab provides numerous features for operator safety.



# Safety-First Working Conditions

## Safe Service Access

The R 9800 is fitted with ergonomic access for fast and safe maintenance. All service points are within reach from one side and at machine level. The R 9800's upperstructure is accessible via a robust fixed ladder or via an optional hydraulic actuated 45° stairway.

## Secure Maintenance

All components have been located allowing effortless inspection and replacement. Numerous service lights are strategically located in the service areas to sustain suitable maintenance conditions, day or night. Emergency stops have been strategically placed in the cab, engine compartment and at ground level. The R 9800 eliminates hazards to ensure a safe environment for the service staff during maintenance.

# Efficient Machine Protection

## Protection Against Fire Ignition

The engine compartment has a bulkhead wall to separate the engine from the hydraulic pumps. This reduces the risk of hydraulic oil entering the engine compartment. The turbochargers and exhaust systems are heat shielded, and all hydraulic hoses are made from a highly resistant material to prevent the risk of fires.

## Automatic Fire Suppression System

The R 9800 can be equipped with a fully integrated fire suppression, employing a dual agent solution to prevent and protect the machine. The fire suppression system has both automatic and manual release capabilities, emergency stop devices are strategically located on the machine to be easily accessible in any case by the operator.



## Improved Accessibility Ease of Maintenance

The machine is easily visible even by night or in extremely dusty working environments thanks to:

- 16 long-range working LED lights located on attachment, uppercarriage and counterweight
- Travel alarm system with light and buzzer

## Machine Access

Designed for safe access on the machine upperstructure via:

- A 45° powered stairway and catwalks with handrails and perforated steps
- Walkways with slip-resistant surfaces
- Emergency egress with handrails in front of the excavator
- Optional service folding platform for safe action on front swing gears and attachment pins

## Commitment to Employees Safety

- Safe and protected access to the components
- Major components centralized to be easily accessible
- E-stops located for the operator and maintenance staff
- Maintenance fluids reach at ground level in option
- Rear and Side Vision System





# Environment



## Mining Responsibly

Liebherr considers the preservation of the environment as a major challenge for the present and future. Liebherr take greater account of environmental issues in designing, manufacturing and managing machine's structures. This commitment provides solutions that allow customers to balance high performance with environmental consciousness.



# Minimized Impact on Life

## Optimized Energy Consumption, Fewer Emissions

The intelligent energy management system coordinates optimal interaction between the hydraulic system and engine output with the goal of a maximum performance with a minimum consumption. With the "Eco-Mode", the machine is set up to reduce engine load, improve significantly fuel consumption and optimize emissions.

## Controlled Emission Rejection

The R 9800 is powered by high horsepower diesel engines which comply with the USA/EPA Tier 2 or Tier 4i emission limits. This power drive makes the R 9800 cost effective without compromising productivity whilst reducing the machines impact on the environment.

# Sustainable Design and Manufacturing Process

## Certified Environment Management Systems

Subject to the stringent European program for the regulation of the use of chemical substances in the manufacturing process REACH\*, Liebherr undertakes a global evaluation to minimize the impacts of hazardous material, pollution control, water conservation, energy and environmental campaigns.

## Extended Components and Fluids Lifetime

Liebherr is constantly working on ways to extend component life. Through the Exchange Components program, superior lubrication systems and the reinforcement of parts under stress, Liebherr can reduce frequency of part replacement. The result minimizes environmental impact and lowers the overall cost of ownership.

\*REACH is the European Community Regulation on chemicals and their safe use (EC 1907/2006) It deals with the Registration, Evaluation, Authorization and Restriction of Chemical Substances.



## Remanufacturing Program

- Second life for your major components
- Liebherr certified quality
- Reduced environmental impact
- Reduced costs and investment

## Automatic Idle Control

Electronic idle control of the engine results in:

- Less fuel consumption
- Less load on the engine
- Reduced emissions
- More comfort to the operator (reduced noise pollution)

## Electric Drive Version

The electric drive system is an efficient alternative to diesel engine allowing:

- Less vibration resulting in higher component lifetime
- Lower maintenance costs
- Less noise pollution
- No exhaust gas emissions
- High motor efficiency
- Maximum efficiency in cold climate conditions when combined with the Arctic Kit



# Technical Data

## Engine

### 2 Cummins diesel engines

Rating per SAE J1995	2 x 1,492 kW / 2 x 2,000 HP at 1,800 rpm
Model	Cummins QSK60 (USA/EPA Tier 2, Tier 4i or fuel consumption optimized setting)
Type	16 cylinder V-engine
Bore/Stroke	159/190 mm / 6.26/7.48 in
Displacement	60 l/3,661 in <sup>3</sup>

or

### 2 MTU diesel engines

Rating per ISO 3046	2 x 1,425 kW / 2 x 1,910 HP at 1,800 rpm
Model	12V4000 (USA/EPA Tier 2, Tier 4i or fuel consumption optimized setting)
Type	12 cylinder V-engine
Bore/Stroke	170/210 mm / 6.69/8.26 in
Displacement	57,2 l/3,490 in <sup>3</sup>

**Engine cooling system** fans driven via hydraulic piston motors

**Air cleaner** dry-type air cleaner with pre-cleaner, with automatic dust ejector, primary and safety elements

**Fuel tank** 17,597 l/4,649 gal

**Fuel filtration** 2 stage fuel filtration with water separator and electric priming pump

**Engine lubrication** Cummins: ELIMINATOR™, combination full flow and centrifugal system that eliminates the need for disposable oil filters  
MTU: SPIN™, on filters (4 x) + little centrifugal

### Electrical system

Voltage	24 V
Batteries	8 x 170 Ah / 12 V (Cummins) / 12 x 170 Ah / 12 V (MTU) starting battery 4 x 170 Ah / 12 V service systems
Alternator	2 x 24 V / 260 Amp (brushless)

**Engine idling** electronically controlled

**Electronic engine power management** engine power and speed sensing over the entire engine rpm range

## Electric Motor (optional)

### 2 electric motors

<b>Power output</b>	2 x 1,700 kW / 2 x 2,280 HP
<b>Type</b>	3-phase AC squirrel cage motor
<b>Voltage</b>	6,600 V, other voltage on request
<b>Frequency</b>	50 Hz (or 60 Hz)
<b>Revolutions</b>	1,500 rpm or 1,800 rpm
<b>Motor cooling</b>	integrated air-to-air heat exchanger
<b>Starting method</b>	inrush current limited to 2.2 full load current
<b>Starting sequence</b>	successive startup of electric motors

## Swing Drive

<b>Hydraulic motor</b>	4 Liebherr axial piston motors
<b>Swing gear</b>	4 Liebherr planetary reduction gears
<b>Swing ring</b>	Liebherr, sealed triple roller swing ring, internal teeth
<b>Swing speed</b>	0 – 3.6 rpm
<b>Swing-holding brake</b>	4 hydraulically released, maintenance-free, external multi-disc brakes

## Electro-Hydraulic Controls

<b>Servo circuit</b>	independent, electronic over hydraulic proportional controls of each function
Emergency control	emergency lowering of the attachment to the ground
<b>Power distribution</b>	via monoblock control valves with integrated primary relief valves and flanged on secondary valves for travel and with integrated proportional and safety valves to attachment and travel drive
Flow summation	
<b>Electro-hydraulic servo control</b>	
Attachment and swing	electronic optimized control via proportional valves
Travel	electronic optimized control via proportional valves
Electronic damping system	Liebherr designed electronic control of cylinder end-position

## Hydraulic System

<b>Hydraulic pump</b>	
for attachment and travel drive	10 variable flow axial piston pumps
Max. flow	10 x 750 l/min. / 10 x 198 gpm
Max. pressure	320 bar / 4,640 psi
for swing drive	4 reversible swashplate pumps, closed-loop circuit
Max. flow	4 x 535 l/min. / 4 x 141 gpm
Max. pressure	320 bar / 4,640 psi
<b>Pump management</b>	electronically controlled pressure and flow management with oil flow optimisation
<b>Hydraulic tank capacity</b>	5,800 l / 1,532 gal
<b>Hydraulic system capacity</b>	10,000 l / 2,642 gal
<b>Hydraulic oil filter</b>	1 high pressure safety filter after each main pump + fine filtration of entire return flow (15/5 µm)
<b>Hydraulic oil cooler</b>	4 separate coolers, 4 temperature controlled fans driven via hydraulic piston motors

## Electric System

<b>Electric isolation</b>	easy accessible battery isolations
<b>Working lights</b>	LED lights: – 4 on working attachment – 4 on RHS of uppercarriage – 4 on LHS of uppercarriage – 2 on counterweight – 2 on cab
<b>Emergency stop switches</b>	at ground level, in hydraulic compartment, in engine and pumps compartment and in operator cab
<b>Electrical wiring</b>	heavy duty execution in IP 65 standard for operating conditions of –50 °C to 100 °C / –58 °F to 212 °F

## Uppercarriage

<b>Design</b>	torsion resistant designed upper frame in box-type construction for superior strength and durability
<b>Attachment mounting</b>	parallel longitudinal main girders in box section construction
<b>Machine access</b>	45° access system with handrails on the cab side of the uppercarriage, full controlled descent, in case of emergency stop additional emergency ladder fitted near the cab + emergency rope ladder in pump compartment





## Operator's Cab

<b>Design</b>	resiliently mounted, sound insulated, large windows for all around visibility, integrated falling object protection FOPS
<b>Operator's seat</b>	suspended pneumatic seat, body-contoured with shock absorber, adjustable to operator's weight, additional "retractable passenger/trainer seat" seat heating
<b>Cabin windows</b>	20.5 mm/0.8 in tinted armored glass for front window and 18 mm/0.7 in for right-hand side windows, all other windows in tinted safety glass, high pressure windshield-washer system with 75 l/20 gal water-tank, sun louvers on all windows in heavy duty design
<b>Heating system / Air conditioning</b>	heavy duty, fully automatic, high output air conditioner and heater unit
<b>Cabin pressurization</b>	ventilation unit with filters
<b>Controls</b>	joystick levers integrated into armrest of seat, armrest adjusted to seat position
<b>Display</b>	10.5 in color LCD-display with low and high brightness settings
<b>Condition monitoring</b>	machine condition monitoring system with error reporting and operational information
<b>Rear vision system</b>	camera installation on counterweight and right-hand side of the uppercarriage displayed over an additional LCD-display
<b>Safety function</b>	Automatic engine shut off engine self-controlled power limitation and shut off
<b>Safety functions</b>	additional gauges with constant display for: engine speed, hourmeter, voltmeter, safety mode for engine speed control and pump regulation
<b>Noise level (ISO 6396)</b>	Diesel: $L_{pA}$ (inside cab) = 76 dB(A) Cummins = 79 dB(A) MTU with oil/water fans at 100% and AC fan at 65%



## Undercarriage

<b>Design</b>	3-piece undercarriage, box-type structure for center piece and side frames, stress relieved
<b>Hydraulic motor</b>	3 axial piston motors per side frame
<b>Travel gear</b>	Liebherr planetary reduction gear
<b>Travel speed</b>	Diesel: 0 – 2,0 – 2,6 km/h/0 – 1.2 – 1.6 mph Electric: 0 – 1,7 km/h/0 – 1.05 mph
<b>Parking brake</b>	spring engaged, hydraulically pressure released external wet multi-disc brakes for each travel motor, maintenance-free
<b>Track components</b>	maintenance-free dual pin cast link and pad combined
<b>Track rollers / Carrier rollers</b>	6/3 per side frame
<b>Automatic track tensioner</b>	pressurized hydraulic cylinder with accumulator, maintenance free
<b>Transport</b>	undercarriage side frames are removable



## Service Flap

<b>Design</b>	hydraulically actuated service flap, easily accessible from ground level to including: <ul style="list-style-type: none"> <li>– 2 fast fuel refill lines</li> <li>– hydraulic oil refill and drainage</li> <li>– engine oil exchange</li> <li>– splitterbox oil exchange</li> <li>– swing gearbox oil exchange (4 x draining/4 x refill)</li> <li>– swing ring teeth grease barrel refilling with grease filter</li> <li>– attachment/swing ring bearing grease barrel refilling with grease filter</li> <li>– windshield washer water refilling</li> <li>– oil reserve system refilling (optional)</li> <li>– different couplings available on request</li> </ul>
---------------	--



## Central Lubrication System

<b>Type</b>	single-line lubrication system for the entire attachment/swing ring bearing and teeth
<b>Grease pumps</b>	2 hydraulic grease pumps for attachment/swing ring bearing lubrication with switch over function and 1 hydraulic grease pump for swing ring teeth lubrication
<b>Capacity</b>	600 l/158.5 gal bulk container for attachment/swing ring bearing, separated 80 l/21 gal container for swing ring teeth
<b>Refill</b>	via the service flap for both containers with grease filters



## Attachment

<b>Design</b>	box-type structure with large steel castings in all high-stress areas
<b>Stick Pivots</b>	wear protection underneath lower beam plate two floating pins per pivot, sealed covers, all bearings with wear resistant steel bushings, bolts hardened and chromium-plated
<b>Hydraulic cylinder</b>	Liebherr design, electronically controlled end-cushioning
<b>Hydraulic connections</b>	pipes and hoses equipped with SAE connections
<b>Pivots bucket-to-stick</b>	O-ring sealed and completely enclosed
<b>Pivots bucket-to-link</b>	
<b>Lubrication</b>	connected to the centralized lubrication system, each lubrication point independently lubricated



# Dimensions

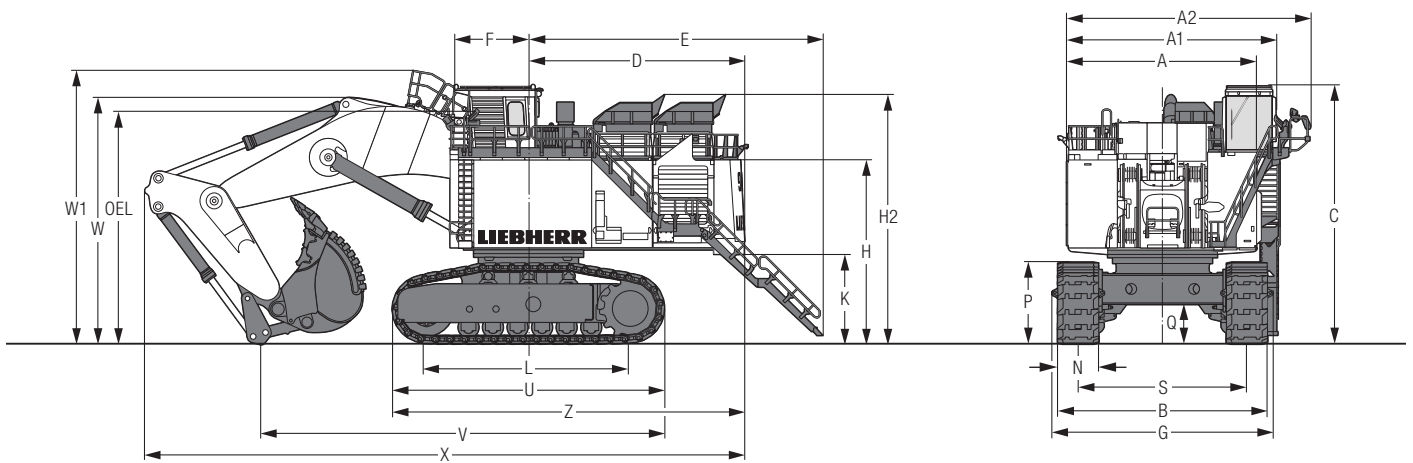

	mm/ft in
A	7,550/24' 9"
A1	8,408/27' 6"
A2	8,880/29' 1"
B	8,330/27' 3"
C	10,338/33'10"
D	8,600/28' 2"
E	11,697/38' 4"
F	2,955/ 9' 8"
G	8,778/28' 9"
H	7,347/24' 1"
H2	9,915/32' 6"
K	3,597/11' 9"

	mm/ft in
L	8,098/26' 6"
N	1,630/ 5' 4"
P	3,261/10' 8"
Q	1,574/ 5' 1"
S	6,700/21'11"
U	10,846/35' 6"
V	16,055/52' 7"
W	9,834/32' 3"
W1	11,063/36' 3"
X	23,907/78' 4"
Z	14,023/45'11"
OEL	Operator's eye level 8,800/28'10"

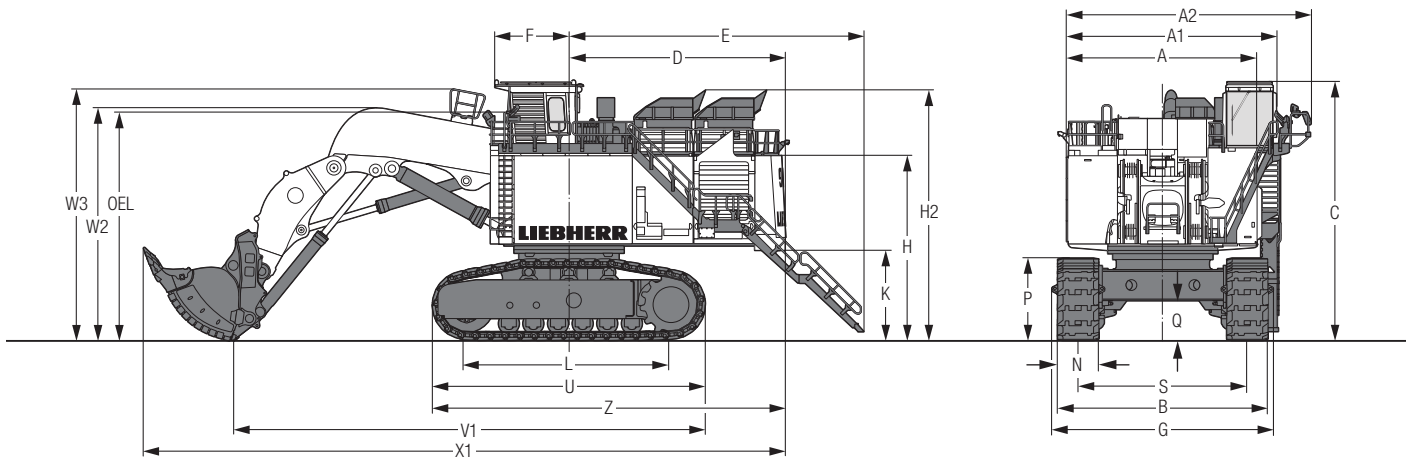

	mm/ft in
A	7,550/24' 9"
A1	8,408/27' 6"
A2	8,800/28'10"
B	8,330/27' 3"
C	10,338/33'10"
D	8,600/28' 2"
E	11,697/38' 4"
F	2,955/ 9' 8"
G	8,778/28' 9"
H	7,347/24' 1"
H2	9,915/32' 6"
K	3,597/11' 9"

	mm/ft in
L	8,098/26' 6"
N	1,630/ 5' 4"
P	3,261/10' 8"
Q	1,574/ 5' 1"
S	6,700/21'11"
U	10,846/35' 6"
V1	18,700/61' 3"
W2	9,780/32' 1"
W3	10,300/33' 8"
X1	25,530/83' 8"
Z	14,023/45'11"
OEL	Operator's eye level 8,800/28'10"



# Backhoe Attachment

with Mono Boom 11.75 m/38'6"

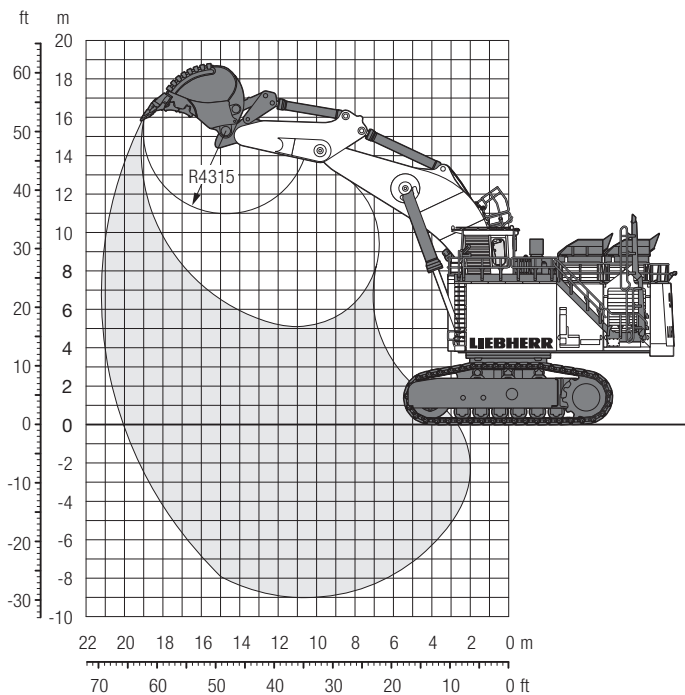

## Digging Envelope

Stick length	5.00 m/16' 4"
Max. digging depth	9.00 m/29' 6"
Max. reach at ground level	20.10 m/65'11"
Max. dumping height	10.90 m/35' 9"
Max. teeth height	16.20 m/53' 1"
Max. digging force (ISO 6015)	1.760 kN/395,664 lbf
Max. breakout force (ISO 6015)	1.980 kN/445,121 lbf

## Operating Weight and Ground Pressure

The operating weight includes the basic machine with standard backhoe attachment and backhoe bucket 42.00 m<sup>3</sup>/54.9 yd<sup>3</sup>.

Pad width	mm / ft in	1,630 / 5'4"
Weight	kg / lb	800,000 / 1,763,700
Ground pressure*	kg/cm <sup>2</sup> / psi	2.71 / 38.45

\* according to ISO 16754

## Backhoe Buckets for Machine in Standard Configuration

For materials class according to VOB, Section C, DIN 18300	5 – 6	5 – 6	5 – 6	5 – 6
Typical operation according to VOB Section C, DIN 18300	HD	HD	HD	HD
Capacity ISO 7451	m <sup>3</sup> 40.00	42.00	45.00	47.50
	yd <sup>3</sup> 52.3	54.9	58.9	62.1
Suitable for material up to a specific weight of	t/m <sup>3</sup> 1.9	1.8	1.7	1.6
	lb/yd <sup>3</sup> 3,204	3,035	2,867	2,698
Cutting width	mm 4,800	4,800	4,800	4,800
	ft in 15'8"	15'8"	15'8"	15'8"
Weight	kg 45,000	45,150	42,550	43,650
	lb 99,208	99,539	93,807	96,232

## Backhoe Buckets for Machine with High Performance Option

For materials class according to VOB, Section C, DIN 18300	5 – 6	5 – 6	5 – 6	5 – 6
Typical operation according to VOB Section C, DIN 18300	HD	HD	HD	HD
Capacity ISO 7451	m <sup>3</sup> 45.00	47.50	50.00	52.00
	yd <sup>3</sup> 58.9	62.1	65.4	68.0
Suitable for material up to a specific weight of	t/m <sup>3</sup> 1.9	1.8	1.7	1.6
	lb/yd <sup>3</sup> 3,204	3,035	2,867	2,698
Cutting width	mm 4,800	4,800	4,800	4,800
	ft in 15'8"	15'8"	15'8"	15'8"
Weight	kg 39,100	39,630	40,300	41,000
	lb 86,201	87,369	88,846	90,389

HD: Heavy-duty bucket

Other buckets for other densities and/or material class on request

# Face Shovel Attachment

with Shovel Boom 8.55 m/28'

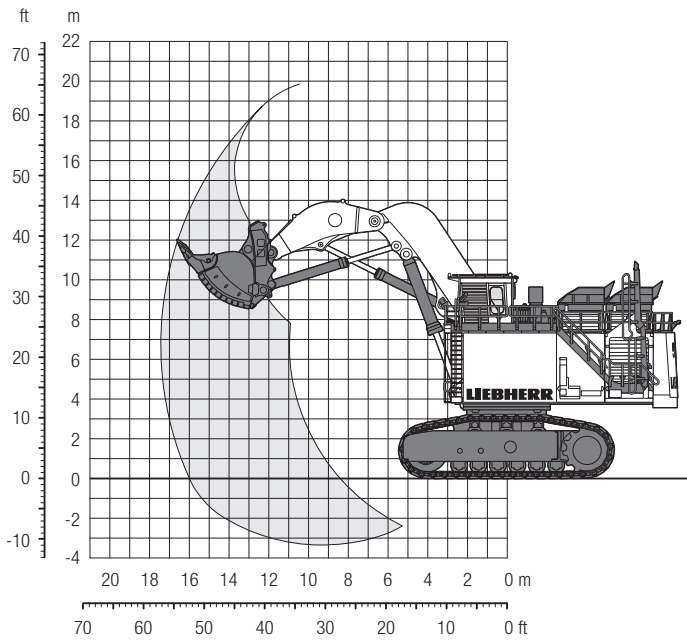

## Digging Envelope

Stick length	5.45 m/17' 9"
Max. reach at ground level	16.00 m/52' 5"
Max. dumping height	12.40 m/40' 7"
Max. crowd length	5.40 m/17' 7"
Bucket opening width T	3,00 m/ 9'10"
<hr/>	
Crowd force at ground level (ISO 6015)	2,900 kN/651,946 lbf
Max. crowd force (ISO 6015)	3,000 kN/674,427 lbf
Max. breakout force (ISO 6015)	2.395 kN/538,417 lbf

## Operating Weight and Ground Pressure

The operating weight includes the basic machine with shovel attachment and bucket 42.00 m<sup>3</sup>/54.9 yd<sup>3</sup>.

Pad width	mm/ft in	1,630/5'4"
Weight	kg/lb	810,000/1,785,700
Ground pressure*	kg/cm <sup>2</sup> /psi	2.74/38.94

\* according to ISO 16754

## Face Shovel Buckets

For materials class according to VOB, Section C, DIN 18300	7 – 8	5 – 6	5 – 6	5 – 6
Typical operation according to VOB Section C, DIN 18300	XHD	HD	HD	HD
Capacity ISO 7451	m <sup>3</sup> 38.00	40.00	42.00	44.00
	yd <sup>3</sup> 49.7	52.3	54.9	57.5
Suitable for material up to a specific weight of	t/m <sup>3</sup> 2.0	1.9	1.8	1.7
	lb/yd <sup>3</sup> 3,373	3,204	3,035	2,867
Cutting width	mm 5,600	5,600	5,600	5,600
	ft in 18'4"	18'4"	18'4"	18'4"
Weight	kg 75,000	75,300	75,500	78,000
	lb 165,347	166,008	166,449	171,960

HD: Heavy-duty bucket

XHD: Heavy-duty rock bucket

Other buckets for other densities and/or material class on request



# Optional Equipment

## Undercarriage

Different track pad width  
Full length chain guide  
Travel motor guard with access hatch  
Undercarriage bottom cover

## Uppercarriage

Rock protection for fuel tank  
Swing ring scraper  
Wiggins/Banlaw/other brand name fast refilling system  
Wiggins/Banlaw/other brand name counter plugs (service trucks)  
Service folding platform  
Electric incinerating toilet  
Slewing ring with 90° installation arrangement

## Hydraulic System

Oil cooler inlet screens

## Engine

Fuel consumption optimized engine version (Tier non-certified)  
Cummins oil reserve system  
Pre-filter for engine oil refilling

## Operator's Cab

4-point seat belt  
Additional back and side wipers  
Double A/C system  
Front protective grid

## Attachment

High performance option

## Specific Solutions

Arctic package (-30 °C/-22 °F, -40 °C/-40 °F, -50 °C/-58 °F)  
Sound attenuation package  
High altitude kit

## Safety

Automatic fire suppression system  
Installation kit for extra cameras  
Additional camera/display for double side loading

## General

Maritime transport packaging

# The Liebherr Group of Companies

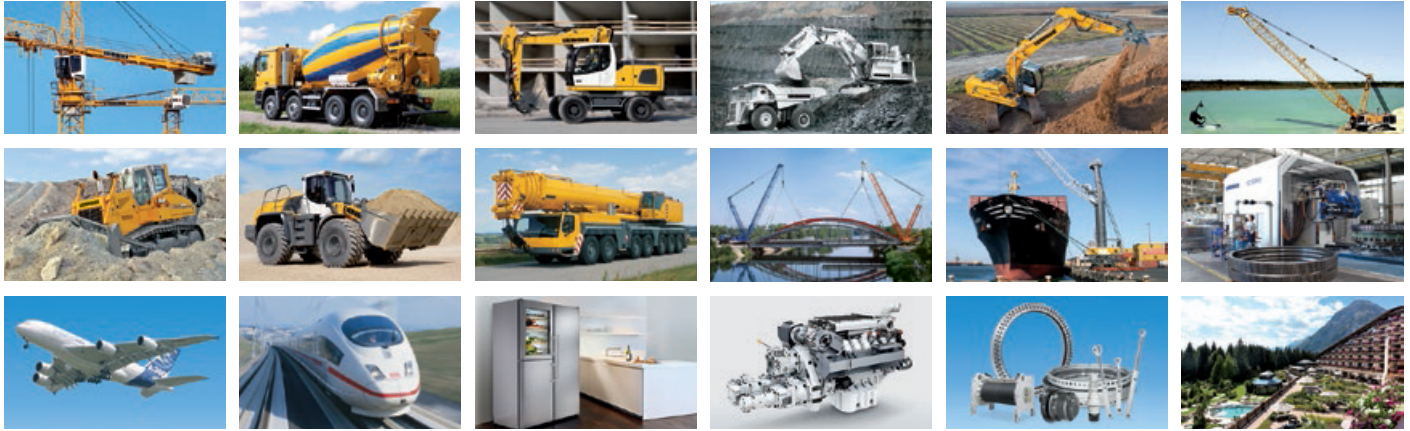

## Wide Product Range

The Liebherr Group is one of the largest construction equipment manufacturers in the world. Liebherr's high-value products and services enjoy a high reputation in many other fields. The wide range includes domestic appliances, aerospace and transportation systems, machine tools and maritime cranes.

## Exceptional Customer Benefit

Every product line provides a complete range of models in many different versions. With both their technical excellence and acknowledged quality, Liebherr products offer a maximum of customer benefits in practical application.

## State-of-the-art Technology

To provide consistent, top quality products, Liebherr attaches great importance to each product area, its components and core technologies. Important modules and components are developed and manufactured in-house, for instance the entire drive and control technology for construction equipment.

## Worldwide and Independent

Hans Liebherr founded the Liebherr family company in 1949. Since that time, the enterprise has steadily grown to a group of more than 130 companies with over 41,000 employees located on all continents. The corporate headquarters of the Group is Liebherr-International AG in Bulle, Switzerland. The Liebherr family is the sole owner of the company.

[www.liebherr.com](http://www.liebherr.com)