

Mining Excavator

R 9200

Operating Weight with
Backhoe Attachment:
205 tonnes / 225 tons

Shovel Attachment:
210 tonnes / 231 tons

Engine:
810 kW / 1,086 HP

Bucket Capacity:
12.5 m³ / 16.3 yd³

Shovel Capacity:
12.5 m³ / 16.3 yd³



LIEBHERR

R 9200

Operating Weight with Backhoe Attachment:

205 tonnes/225 tons

Shovel Attachment:

210 tonnes/231 tons

Engine:

810 kW/1,086 HP

Bucket Capacity:

12.5 m³/16.3 yd³

Shovel Capacity:

12.5 m³/16.3 yd³



Productivity

Working Harder and Faster



Efficiency

Moving More for Less





Reliability

Ready to Work
When You Need It



Customer Service

Worldclass Support,
Everywhere, Every Day



Safety

Protecting Your Most
Important Assets



Environment

Mining Responsibly





Productivity



Working Harder and Faster

The R 9200 is the optimal loading tool to pair with 100 t and 140 t off-highway trucks. The R 9200 is a world-class loading tool to meet mining customer's expectations with leading-edge technology. R 9200 delivers this in three ways: high productivity, exceptional reliability, and true 200 t class performance.

Fast and Precise Movement

Proven Mining Engine

The R 9200 is powered by a single Cummins QSK38 diesel engine which is USA/EPA Tier 2 or Tier 4i compliant. Renowned for its reliability, the engine delivers durable and superior performance contributing to achieve production goals. Liebherr's deliberate choice of the proven Cummins engine is due to the efficient proactive service on-site and continued collaboration with Cummins.

Easy Machine Control

The R 9200 is designed with user friendly controls featuring an advanced electronic piloting system, which promotes an intuitive and versatile control resulting in increased productivity.

Fast Cycle Time

Like all other Liebherr mining excavators, the R 9200 uses a closed-loop swing circuit. The main hydraulic circuit comprises a combination of four independent main valves fed by four working pumps, providing unrivaled flexibility of attachment control and force distribution, while allowing full oil flow integration for fast movement and lowest cycle times.

Cab Optimized for Performance

Accessibility, comfort and safety define the standard of the new Liebherr cab for the R 9200. A panoramic view combined with cameras system allow the operator to have in any case the control of the working environment. The seat, joysticks and pedals are designed and located to increase the result of the operator while reducing fatigue.

Highest Digging and Breakout Force

As a result of the highest digging and breakout forces in its class, the R 9200 provides fast and efficient filling of the bucket, even in extreme digging conditions.



Single Driveline Concept

- Cummins QSK38 USA/EPA Tier 2 or Tier 4i Compliant
- Automatic idling system and engine shutdown
- Fuel pre-filter with water separator
- Max. altitude without deration: 3,600 m
- Fuel consumption optimized (option)

Exclusive Bucket Solution

- Innovative Liebherr bucket design to maximize bucket fill factor
- Optimized Liebherr GET and wear package according to customer application
- Ensure optimal penetration efficiency
- Single GET hammerless locking system for safe and easy maintenance
- Fully patented GET system design for optimal penetration/lifetime
- Four tooth profiles available for various range of applications

Ergonomic Cab Design

- Elevated and armored cab installation
- User-friendly piloting station
- Screen located for convenient operator viewing
- Passenger seat for trainer, mechanical engineer or geologist
- Additional protection offered



Efficiency



Moving More for Less

The R 9200 follows the Liebherr philosophy of maximizing performance by improving the efficiency of all individual subsystems. The advanced regulation system allows a well-balanced energy consumption reducing operating costs per ton. In addition, all components work in optimal performance range that contributes to extend their life for the highest machine availability.

Advanced Energy Optimization

Closed Loop Swing Circuit

The R 9200 is the only 200 t class mining excavator using a closed loop swing circuit. The kinematic energy can be saved when the swing motion is used during deceleration, to drive the main and auxiliary pumps, reducing fuel consumption and allowing faster boom lift motion.

Litronic Plus

The Liebherr-patented Litronic Plus system consists of an intelligent power management system specially developed to optimize electrical, mechanical and hydraulic power distribution. This system encourages fuel efficiency and energy savings while ensuring peak subsystem performance according to immediate working requirements.

Independent Cooling System

Oil and water cooling fans are independent and electronically managed. The on-demand cooling control enables to maximize available power for the working process. This technology contributes to maintain sustainable temperature of all the hydraulic components extending their life.

Top-Class Components Access

The R 9200 was developed to facilitate the maintenance of the components of the machine. For example, the hydraulic valve blocks are located on the uppercarriage and easily accessible from the service platform, and numerous filters are centrally located to allow faster access. With a wide area of maintenance around the engine and the pumps, the R 9200 offers a great environment to the service staff to reduce at the minimum the service time of the machine.

Extended Components Lifetime

The hydraulic oil filtration systems remove fluid contaminants to offer the highest rate of hydraulic components durability. To maintain oil quality, all return hydraulic oil flow goes through a fine filtration system (15/5 μm) and oil tank is sized to considerably extend the time between service intervals.



Advanced Machine Monitoring

- 10.5 inch LCD color 8-key screen
- On-board diagnostics data for service staff
- Permanent rear and side vision
- Information interface to operator (engine, steering, attachment, hydraulic, etc.)

Central Service Station

- Fuel, engine oil, grease system, hydraulic oil, etc.
- Manually actuated service flap
- Fitted with Wiggins couplings
- Banlaw available as option
- Multiflo Hydraul-Flo as option

High Performance Less losses

- Pressure less boom down function
- High pressure hydraulic circuits
- Newest energy optimized attachment controls
- High diameter hydraulic lines
- Fuel efficiency



Reliability



Ready to Work When You Need It

With over 50 years of innovative thinking, engineering and manufacturing excellence, Liebherr sets the industry standard for advanced equipment design and technology tools to provide the most up-to-date product responding to the requirements of the mining customers.

Quality: the Liebherr Trademark

Structure Made Exclusively for Mining

Liebherr mining excavators are conceptualised, designed and dedicated to the mining industry. The engineering department uses specific 3D solution in order to meet possible requirements, such as Finite Element and Fatigue Life Analysis. In combination, the manufacturing department uses advanced welding techniques to strategically reinforce the structure. The synergy of our skills allows to obtain maximal machine availability.

Reinforced Undercarriage Structure

Specifically designed for extreme mining conditions, the rugged R 9200 undercarriage represents the basis for the stability of the machine. Using specific anti-collision track chain guide and heavy duty track rollers, the chains are maintained in the perfect alignment in any condition. The access to the travel motors and brakes has been designed to provide maximum protection to the components, while providing easy and fast service access.

Liebherr Components Integration

As an OEM, Liebherr has built a solid reputation for development and production of high quality strategic mining components. The R 9200 integrates robust and reliable mining components that are developed, manufactured and controlled by Liebherr, ensuring reliability and high performance for the entire machine.

Suit Customer Requirements

Liebherr sales engineer support during the decision-making stage guarantees that the customised product choice perfectly matches customer requirements. To ensure customer satisfaction, the Liebherr products are available in a range of specific configurations. For example, to upgrade the machine for the cold climate environment, to adapt the undercarriage for an specific application or to increase safety and comfort of the operator. With more than 150 engineers dedicated to develop mining excavators, Liebherr offers tailored-made solution to meet the clients requirements.

Simplified Design

All through the R 9200 meets all the entire market requirements concerning life cycle cost and productivity, all system and design solutions have been simplified to the straight minimum. This increases reliability and facilitates significantly maintenance and troubleshooting. The result is less downtime and reliable availability.



Quality Commitment

- Liebherr-Mining Equipment Colmar, France, ISO 9001 certified
- Compliance of materials tested in laboratory
- Quality control during the stages of production
- Vertical integration practice

Liebherr Component Integration

- Hydraulic pumps and motors
- Electronic and control technology
- Swing and travel drives
- Hydraulic cylinders
- Splitter box
- Swing ring

Strengthened Attachment Design

- Designed for maximum structure life
- Use of advanced welding techniques
- Hard rock protections as options



Customer Service



Worldclass Support, Everywhere, Every Day

By partnering with our customers, Liebherr implements tailored solutions from technical support, spare parts and logistics solutions to global maintenance for all types of equipment, all over the world.

Customer Support

International Service Organization

The Liebherr Service Support has always been an important focus for the company. Complete service during all operating phases from machinery installation to problem solving, spare parts inventory and technical service. Our service team is close to our customers, delivering the best specific maintenance solution to reduce both equipment downtime and repair costs.

Complete Training Program

From fully trained technicians to a full team of certified field service engineers, Liebherr commits to provide you with world class training. Dedicated to mining, the Liebherr training team provides maintenance staff training programs to allow cost-efficient and safe operations.

Remanufacturing

Reduced Costs and Investment

Over the course of a mining machine's lifetime, major components must be replaced to ensure continued safety, productivity and reliability. The Liebherr Mining Remanufacturing Program offers customers an OEM alternative to purchasing brand new replacement components. Enabling customers to achieve lowest possible equipment lifecycle costs without compromising quality, performance or reliability.

Fast Availability

A international service network and component facilities worldwide means that component repair services and exchange components are available to customers regardless of their location.

Parts Business

Performance

Using genuine Liebherr components ensures the best interaction within your machine, encouraging optimal performance and most effective machine operation and you can be sure that you are in line with the latest improvements and updates on parts providing peace-ofmind as all major components are tracked in the Liebherr Maintenance Management System.

Partnership

Liebherr regularly reviews requirements for parts and components for individual machines, based on operating hours, consumption and planned maintenance, resulting in minimized down time for customers. With access to the Global stock via all Liebherr Mining Warehouses, you will improve productivity by having the part you need, when you need it.

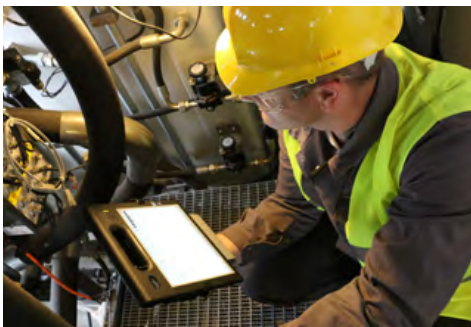

Troubleshoot Advisor Platform

- Unique maintenance system to help you identify problems
- Easy and friendly-user interface
- Compatible with mobile, tablet or laptop
- Regular updating of the database
- Procedures described by specialist with images and videos

Repair and Remanufacturing Programs

- Liebherr certified quality
- As-new warranty
- OEM expertise
- Reduced costs and investment
- Fast availability

Easy Access Parts Online

- Available any time anywhere
- User friendly interface
- Online ordering
- Save time and money



Safety



Protecting Your Most Important Assets

The Liebherr R 9200 provides uncompromising safety for operators and maintenance crews. Equipped with the service flap accessible from the ground level and integrating wide open accesses, the R 9200 allows quick and safe maintenance. The R 9200 cab provides numerous features for operator safety.

Safety-First Working Conditions

Safety-First Cab Design

Operator safety is one of the main concerns in designing and developing the new R 9200. A panoramic view, low noise level, strong structure and safety glass are elements that ensure compliance with international safety standards. In addition, Liebherr provides supplementary options allowing the cab to be adapted to your specific safety standards.

Secure Maintenance

All components are designed to allow effortless inspection and replacement. Numerous service lights are strategically located in service areas to maintain suitable maintenance conditions, day or night. Emergency stops have been strategically placed in the cab, engine compartment and at ground level. The R 9200 eliminates hazards to ensure a safe environment for the service staff during maintenance.

Efficient Machine Protection

Protection Against Fire Ignition

The engine compartment has a bulkhead wall to separate the engine from the hydraulic pumps. This reduces the risk of hydraulic oil entering the engine compartment. The turbochargers and exhaust systems are heat shielded, and all hydraulic hoses are made from a highly resistant material to prevent the risk of fires.

Automatic Fire Suppression System

The R 9200 can be equipped with a fully integrated fire suppression, employing a dual agent solution to prevent and protect the machine. The fire suppression system has both automatic and manual release capabilities, emergency stop devices are strategically located on the machine to be easily accessible in any case by the operator.



Improved Accessibility

Ease of Maintenance

- 45° stairway
- All walkways with slip-resistant surfaces
- Emergency ladder available near the cab
- Wide open service access
- 8 service / access LED / halogen headlights (full LED optional)

Working

Environment Control

- Rear and side camera system
- LCD color screen display
- 4 Long-range working halogen lights (LED optional)

Commitment to

Employees Safety

- Safe and protected access to the components
- Major components centralized to be easily accessible
- Maintenance fluids reachable at ground level
- E-stops located for the operator and maintenance staff



Environment



Mining Responsibly

Liebherr considers the conservation and preservation of the environment as a major challenge for the present and future. Liebherr are considerate of environmental issues in designing, manufacturing and managing machine structures, providing solutions that allow customers to balance performance with environmental consciousness.

Reduce and Control Emissions

Optimized Energy Consumption, Fewer Emissions

The intelligent energy management system coordinates optimal interaction between the hydraulic system and engine output with the goal of maximum performance with minimum fuel consumption. "Eco-Mode", the machine is set up to reduce engine load, improve significantly fuel consumption and optimize emissions.

Controlled Emission Rejection

The R 9200 is powered by a high horsepower diesel engine which complies with the USA/EPA Tier 2 or Tier 4i compliant emission limits. This power drive makes the R 9200 cost effective without compromising productivity and also reduces impact on the environment.

Sustainable Design and Manufacturing Process

Certified Environment Management Systems

Subject to the stringent European program for the regulation of the use of chemical substances in the manufacturing process REACH*, Liebherr undertakes a global evaluation to minimize the impacts of hazardous material, pollution control, water conservation, energy and environmental campaigns.

Extended Components and Fluids Lifetime

Liebherr is constantly working on ways to extend component life. Through the Exchange Components program, superior lubrication systems and the reinforcement of parts under stress, Liebherr can reduce frequency of part replacement. The result minimizes environmental impact and lowers the overall cost of ownership.

*REACH is the European Community Regulation on chemicals and their safe use (EC 1907/2006) It deals with the Registration, Evaluation, Authorization and Restriction of Chemical Substances.



Remanufacturing Program

- Reduced environmental impact
- Second life for your components
- Alternative to purchase brand-new replacement components

Eco-Mode

- Improved fuel efficiency
- Less noise pollution
- Less carbon dioxide emissions

Sustainable Manufacturing Process

- Promoted recovery-waste management
- Controlled non-recyclable waste elimination
- Eco-friendly material selection (95% of material used on machine is recyclable)
- European certifications

Technical Data

Engine

Rating per SAE J1995	810 kW (1,086 HP) at 1,800 rpm
Model	Cummins QSK38 (USA/EPA Tier 2, Tier 4i or fuel consumption optimized setting)
Type	12 cylinder V-engine
Bore/Stroke	159/159 mm / 6.26/6.26 in
Displacement	37.8 l/2,307 in ³
Aspiration	turbocharged after cooled
Fuel tank	4,500 l/1,189 gal
Electrical system	
Voltage	24 V, 25 V additional
Batteries	4 x 180 Ah/12 V
Alternator	24 V/260 Amp
Engine idling	automatic engine idling
Automatic engine shut off protection	engine self-controlled shut off 3 min.
Water cooler	cooler with temperature controlled fans driven via hydraulic piston motor

Electric Motor (optional)

1 electric motor	
Power output	810 kW/1,086 HP
Type	3 phase AC squirrel cage motor
Voltage	6,000 V, other voltage on request
Frequency	50 Hz (or 60 Hz)
Revolutions	1,500 rpm or 1,800 rpm
Motor cooling	integrated air-to-air heat exchanger
Starting method	inrush current limited to 2,2 full load current

Electro-Hydraulic Controls

Servo circuit	independent, electric over hydraulic proportional controls of each function
Emergency control	via accumulator for all attachment functions with stopped engine
Power distribution	via monoblock control valves with integrated primary relief valves and flanged on secondary valves for travel, 4 independent circuits
Flow summation	attachment and travel drive
Control functions	
Attachment and swing	proportional via joystick levers
Travel	proportional via foot pedals

Swing Drive

Hydraulic motor	2 Liebherr axial piston motors
Swing gear	2 Liebherr planetary reduction gears
Swing ring	Liebherr, sealed triple roller swing ring, internal teeth
Swing speed	0 – 5.0 rpm
Swing-holding brake	hydraulically actuated, maintenance-free, multi-disc brakes integrated in each swing gear

Hydraulic System

Hydraulic pump	4 variable flow axial piston pumps
for attachment and travel drive	
Max. flow	4 x 512 l/min./4 x 135 gpm
Max. pressure	350 bar/5,076 psi
for swing drive	1 reversible swashplate pump, closed-loop circuit
Max. flow	1 x 640 l/min./1 x 169 gpm
Max. pressure	350 bar/5,076 psi
Pump management	electronically controlled pressure, flow and power management with oil flow optimisation
Hydraulic tank capacity	1,800 l/475 gal
Hydraulic system capacity	3,400 l/900 gal
Hydraulic oil filter	1 high pressure safety filter after each high pressure pump + extra-fine filtration of entire return flow with integrated by-pass filtration (15/5 µm) + dedicated leak-oil filtration
Hydraulic oil cooler	cooler with temperature controlled fans driven via hydraulic piston motor

Electric System

Electric isolation	easy accessible battery isolations
Working lights	high brightness halogen lights: – 2 on working attachment with grid protection – 1 on RHS of uppercarriage with grid protection – 1 on LHS of uppercarriage – LED lights as option other: – 4 pieces 24 V outlets – halogen access lights with timer 5 min. (LED as option) – LED service lights with timer 20 min.
Emergency stop switches	at ground level, in hydraulic compartment, in engine compartment and in operator cab
Electrical wiring	heavy duty execution in IP 65 standard for operating conditions of –50 °C to 100 °C/–58 °F to 212 °F

Uppercarriage

Design	torque resistant designed upper frame in box-type construction for superior strength and durability
Attachment mounting	parallel longitudinal main girders in box section construction
Machine access	hydraulically operated 45° access stair, full controlled descent, in case of emergency stop additional emergency ladder fitted near the cab

Operator's Cab

Design	resiliently mounted, sound insulated, large windows for all around visibility, integrated falling object protection FOPS
Operator's seat	suspended pneumatic seat, body-contoured with shock absorber, adjustable to operator's weight, seat heating, additional "retractable passenger/trainer seat"
Cabin windows	tinted armored glass for front window and right-hand side windows, all other windows in tinted safety glass, windshield-washer system 30 l/8 gal watertank, sun louvers on all windows in heavy duty design optional and frontguard optional
Heating system/ Air conditioning	heavy duty, fully automatic, high output air conditioner and heater unit
Cabin pressurization	ventilation with filter
Controls	joystick levers integrated into armrest of seat
Monitoring	via LCD-display, data memory
Rear vision system	camera installation on counterweight and right-hand side of the uppercarriage, displayed on the monitoring display
Noise level (ISO 6396)	74 dB(A)

Undercarriage

Design	3-piece undercarriage, box-type structures for center piece and side frames, stress relieved
Hydraulic motor	1 axial piston motor per side frame
Travel gear	Liebherr planetary reduction gear
Travel speed	0 – 2.8 km/h/0 – 1.7 mph
Parking brake	hydraulically actuated, maintenance-free, multi-disc brakes for each travel motor
Track components	B 11, maintenance-free, forged double grouser pad
Track rollers/ Carrier rollers	8/2 per side frame
Track tensioner	hydraulic and grease tensioner
Transport	undercarriage side frames are removable

Service Flap

Design	manually actuated service flap, easily accessible from ground level to allow: <ul style="list-style-type: none"> – fuel fast refill – engine oil quick change – attachment/ swing ring bearing grease barrel refilling via grease filter – 2 x swing gear oil refill – 2 x swing gear oil draining – splitterbox oil change – other coupler type on request
---------------	--

Central Lubrication System

Type	single-line lubrication system, for the entire attachment/ swing ring bearing and teeth
Grease pumps	hydraulic grease pump for the attachment/ swing ring bearing, electric grease pump for the swing ring teeth
Capacity	200 l/53 gal bulk container for attachment/ swing ring bearing, separated 15 l/4.0 gal bulk container for swing ring teeth
Refill	via the service flap for both containers, fill line with grease filters
Monitoring	via a specific Liebherr steering module with data memory

Attachment

Design	box-type structure with large steel castings in all high-stress areas
Stick	wear protection underneath lower beam plate
Hydraulic cylinder	Liebherr design, electronically controlled end-cushioning
Hydraulic connections	pipes and hoses equipped with SAE split-flange connections
Pivots bucket-to-stick	O-ring sealed and completely enclosed
Pivots bucket-to-link	
Kinematics	Liebherr parallel face shovel attachment geometry, electronic controlled end-cushioning

Dimensions

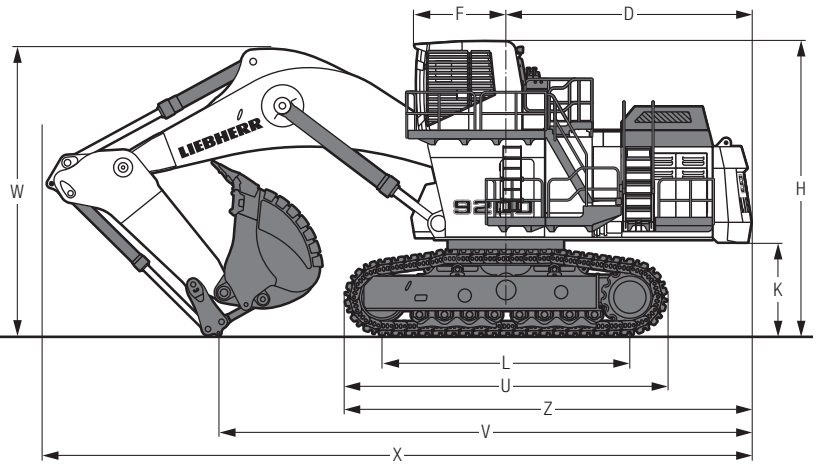
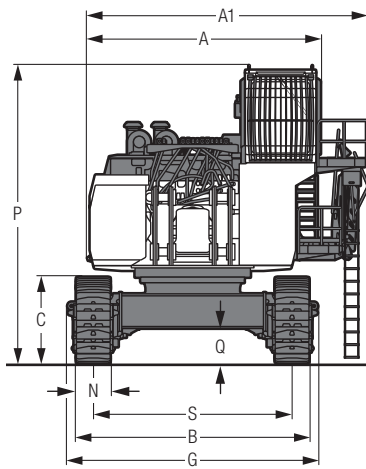

	mm/ft in
A	5,508/18'1"
A1	6,622/21'9"
B	5,502/18'
C	2,031/6'8"
D	5,800/19'
F	2,158/7'1"
G	5,922/19'5"
H	6,930/22'9"
K	2,180/7'2"
L	5,862/19'3"

	mm/ft in
N	800/2'7"
P	6,930/22'9"
Q	832/2'9"
S	4,702/15'5"
U	7,600/24'11"
V	12,600/41'4"
W	7,035/23'1"
X	16,775/55'1"
Z	9,599/31'6"
OEL Operator's eye level	5,980/19'7"

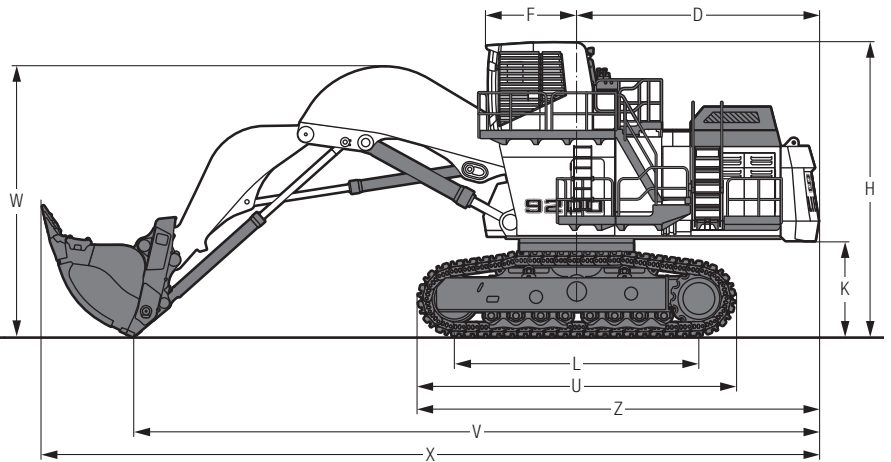
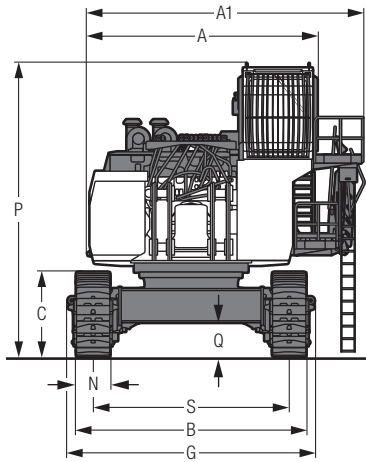

	mm/ft in
A	5,508/18'1"
A1	6,622/21'9"
B	5,502/18'
C	2,031/6'8"
D	5,800/19'
F	2,158/7'1"
G	5,922/19'5"
H	6,930/22'9"
K	2,180/7'2"
L	5,862/19'3"

	mm/ft in
N	800/2'7"
P	6,930/22'9"
Q	832/2'9"
S	4,702/15'5"
U	7,600/24'11"
V	16,420/53'10"
W	6,460/21'2"
X	18,600/61'1"
Z	9,599/31'6"
OEL Operator's eye level	5,980/19'7"

Backhoe Attachment

with Mono Boom 8.50 m / 27'9"

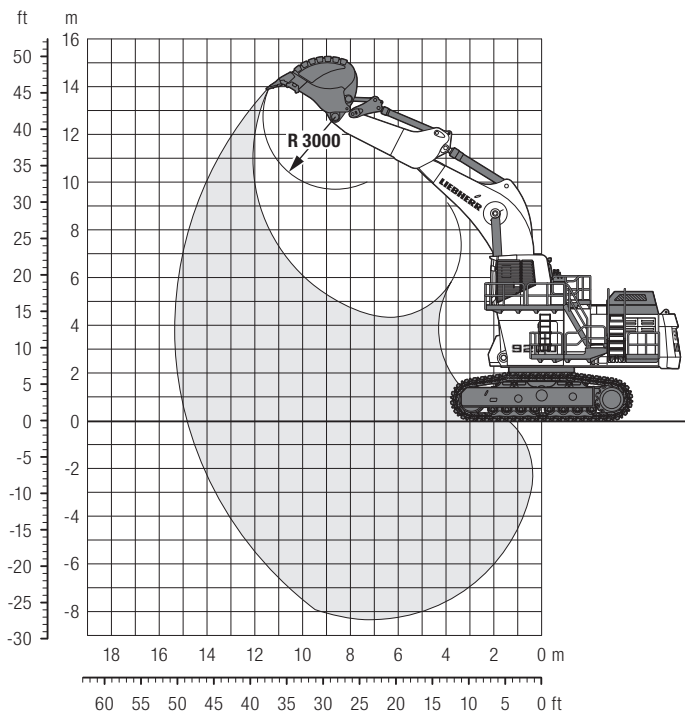

Digging Envelope

Stick length	3.80 m / 12' 5"
Max. digging depth	8.29 m / 27' 2"
Max. reach at ground level	14.82 m / 48' 7"
Max. dumping height	9.71 m / 31' 10"
Max. teeth height	14.03 m / 46'
Max. digging force (ISO 6015)	650 kN / 146,126 lbf
Max. breakout force (ISO 6015)	740 kN / 166,359 lbf

Operating Weight and Ground Pressure

The operating weight includes the basic machine with backhoe attachment and backhoe bucket 12.50 m³ / 16.35 yd³.

Pad width	mm / ft in	800 / 2'6"
Weight	tonnes/tons	205 / 225
Ground pressure*	kg/cm ² / psi	1.98 / 28.16

* according to ISO 16754

Backhoe Buckets

For materials class according to VOB, Section C, DIN 18300	< 5	< 5	< 5	5-6	5-6	5-6	7-8	7-8	7-8
Typical operation according to VOB Section C, DIN 18300	GP	GP	GP	HD	HD	HD	XHD	XHD	XHD
Capacity ISO 7451									
	m ³	15.50	14.60	13.70	13.70	12.50	11.40	11.80	10.00
	yd ³	20.30	19.10	17.90	17.90	16.40	14.90	15.40	13.08
Suitable for material up to a specific weight of									
	t/m ³	1.45	1.55	1.65	1.60	1.80	2.00	1.80	2.25
	lb/yd ³	2,445	2,614	2,782	2,698	3,035	3,373	3,035	3,794
Cutting width									
	mm	3,450	3,250	3,100	3,100	2,800	2,550	2,650	2,350
	ft in	11'3"	10'7"	10'2"	10'2"	9'2"	8'4"	8'8"	7'4"
Weight									
	kg	11,900	11,700	11,500	12,500	12,000	11,400	13,000	12,450
	lb	26,235	25,794	25,353	27,558	26,455	25,133	28,660	27,448

GP: Loading bucket with Liebherr Z110 teeth

HD: Heavy-duty bucket with Liebherr Z120 teeth

XHD: Heavy-duty rock bucket with Liebherr Z120 teeth

Face Shovel Attachment

with Shovel Boom 6.00 m/19'7"

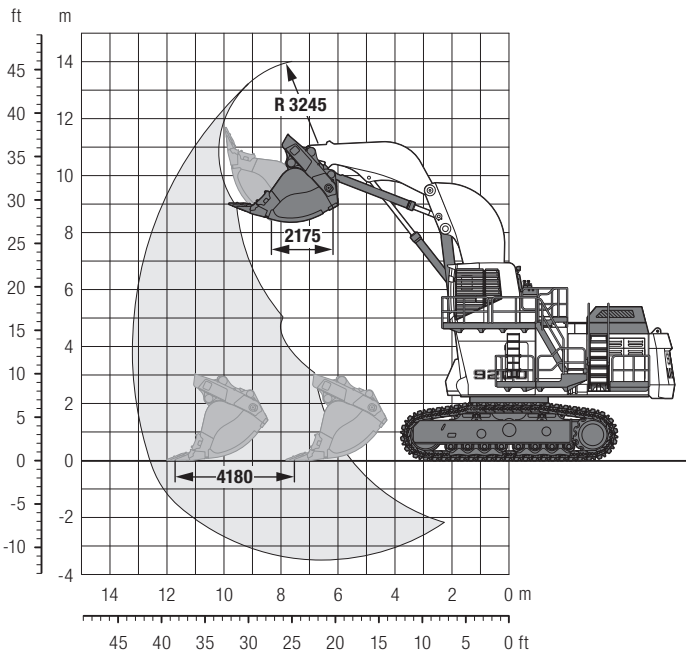

Digging Envelope

Stick length	4.37 m/14'4"
Max. reach at ground level	12.60 m/41'4"
Max. dumping height	8.37 m/27'5"
Max. crowd length	4.18 m/13'8"
Bucket opening width T	2.17 m/ 7'1"
Crowd force at ground level (ISO 6015)	868 kN/195,134 lbf
Max. crowd force (ISO 6015)	924 kN/207,723 lbf
Max. breakout force (ISO 6015)	750 kN/168,606 lbf

Operating Weight and Ground Pressure

The operating weight includes the basic machine with shovel attachment and bucket 12.50 m³/16.35 yd³.

Pad width	mm/ft in	800/2'6"
Weight	tonnes/tons	210/231
Ground pressure*	kg/cm ² /psi	2.02/28.73

* according to ISO 16754

Face Shovel Buckets

For materials class according to VOB, Section C, DIN 18300	< 5	< 5	5 – 6	5 – 6	5 – 6	7 – 8	7 – 8	7 – 8
Typical operation according to VOB Section C, DIN 18300	GP	GP	HD	HD	HD	XHD	XHD	XHD
Capacity ISO 7451								
	m³	14.00	13.50	13.50	12.50	11.50	12.50	11.50
	yd³	18.30	17.70	17.70	16.40	15.00	16.40	15.00
Suitable for material up to a specific weight of								
	t/m³	1.6	1.7	1.6	1.8	2.0	1.7	1.9
	lb/yd³	2,698	2,867	2,698	3,035	3,373	2,867	3,204
Cutting width								
	mm	3,050	3,050	3,050	3,050	3,050	3,050	3,050
	ft in	10'	10'	10'	10'	10'	10'	10'
Weight								
	kg	17,600	17,000	18,400	17,500	17,000	18,750	18,150
	lb	38,801	37,479	40,565	38,581	37,479	41,337	40,014

GP: Loading bucket with Liebherr Z110 teeth

HD: Heavy-duty bucket with Liebherr Z120 teeth

XHD: Heavy-duty rock bucket with Liebherr Z120 teeth

Optional Equipment

Undercarriage

HD travel gear seal for muddy application
Undercarriage bottom cover

Uppercarriage

LED lighting
Multiflo Hydrau-Flo® for fast fueling system
Wiggins/Banlaw counter plugs for fuel/lube trucks
Rock protection for swing gear
Steel grease lines on swing ring
Semi-automatic swing brake with joystick control
Swing ring scrapers
Hydraulic-powered grease refill station

Hydraulic System

Bio-degradable hydraulic oil
Oil cooler inlet screens
Fine filtration bypass (2 µm)

Engine

Fuel consumption optimized engine version
Cold application start aid

Operator's Cab

Front protective grid
Double A/C system
External louvers on back and side cab windows
Operator comfort package
Sliding hatch window on door

Attachment

Piston rod guard for the bucket cylinders
Piston rod guard for hoist cylinders

Specific Solutions

Arctic package (-20 °C/-4 °F, -30 °C/-22 °F, -40 °C/-40 °F, -50 °C/-58 °F)
Sound attenuation package
High altitude kit
Hammer/shear/grapple attachments
Arrangement for object handling operation

Safety

Automatic fire suppression system

The Liebherr Group of Companies

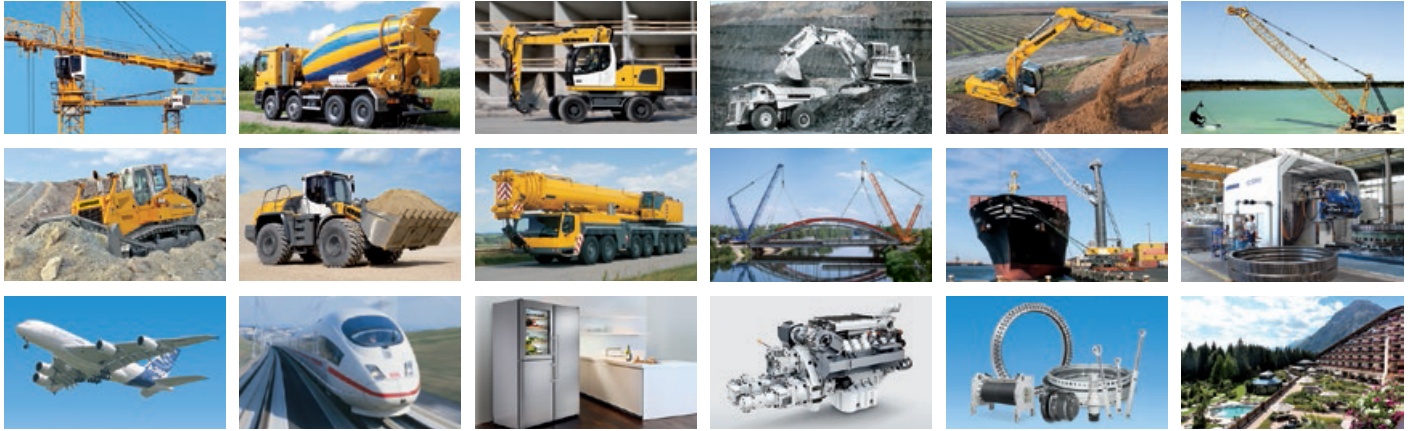

Wide Product Range

The Liebherr Group is one of the largest construction equipment manufacturers in the world. Liebherr's high-value products and services enjoy a high reputation in many other fields. The wide range includes domestic appliances, aerospace and transportation systems, machine tools and maritime cranes.

Exceptional Customer Benefit

Every product line provides a complete range of models in many different versions. With both their technical excellence and acknowledged quality, Liebherr products offer a maximum of customer benefits in practical application.

State-of-the-art Technology

To provide consistent, top quality products, Liebherr attaches great importance to each product area, its components and core technologies. Important modules and components are developed and manufactured in-house, for instance the entire drive and control technology for construction equipment.

Worldwide and Independent

Hans Liebherr founded the Liebherr family company in 1949. Since that time, the enterprise has steadily grown to a group of more than 130 companies with over 41,000 employees located on all continents. The corporate headquarters of the Group is Liebherr-International AG in Bulle, Switzerland. The Liebherr family is the sole owner of the company.

www.liebherr.com